



# Gas-Fired Vented Room Heater



## INSTALLATION AND OPERATING INSTRUCTIONS

P/N 80900 - REV. 10/08



NATURAL GAS	VC201A-H	VC351A-H	VC501A-H	VC701A-H	VCR351A-H	VCR501A-H	VCR701A-H
PROPANE GAS	VC202A-H	VC352A-H	VC502A-H	VC702A-H	VCR352A-H	VCR502A-H	VCR702A-H

This appliance is equipped with a safety control system designed to protect against improper venting of combustion products.

**THIS UNIT IS NOT TO BE INSTALLED IN MOBILE HOMES.**

**WARNING: If the information in this manual is not followed exactly, a fire or explosion may result causing property damage, personal injury or loss of life.**

- Do not store or use gasoline or other flammable vapors and liquids in the vicinity of this or any other appliance.
- **WHAT TO DO IF YOU SMELL GAS:**
  - Do not try to light any appliance.
  - Do not touch any electrical switch; do not use any phone in your building.
  - Immediately call your gas supplier from a neighbor's phone. Follow the gas supplier's instructions.
  - If you cannot reach your gas supplier, call the fire department.
- **INSTALLATION AND SERVICE MUST BE PERFORMED BY A QUALIFIED INSTALLER, SERVICE AGENCY OR THE GAS SUPPLIER.**

RADIANT FRONT

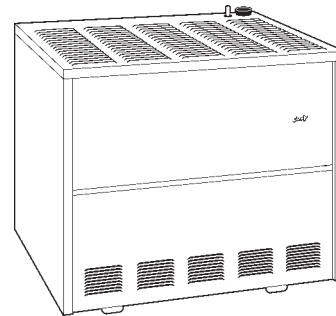
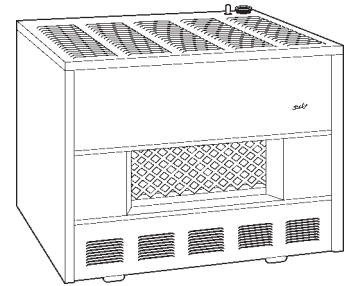

CLOSED FRONT

**INSTALLER:** Leave this manual with the appliance.  
**CONSUMER:** Retain this manual for future reference.

The coating selected to provide longer life to the heat exchanger may smoke slightly upon initial firing. Provide adequate ventilation if this occurs.

**WARNING: Operation of this heater when not connected to a properly installed and maintained venting system or tampering with the vent safety shut-off system can result in Carbon Monoxide (CO) poisoning and possible death.**

**This unit is not approved for installation in mobile homes, greenhouses, or environments involving dusty, wet, corrosive, or explosive conditions. Such conditions will invalidate the warranty and may create unsafe conditions.**

Installation, maintenance, service, troubleshooting and repairs must be performed by a qualified service agency. MR./MRS. HOMEOWNER, **DO NOT** attempt any of these procedures yourself as this could expose you to property damage, personal injury, or loss of life and will invalidate all warranties.

## TABLE OF CONTENTS

SPECIFICATIONS.....	2	RADIANTS & GLASS PANELS.....	8
INTRODUCTION.....	3	BURNER ORIFICE & ORIFICE CHART.....	8
VENTING.....	3,4	PROPER BURNER FLAME.....	9
GAS SUPPLY.....	5	MAINTENANCE.....	9
LOCATION & SPECIAL PRECAUTIONS	5	LIGHTING INSTRUCTIONS.....	10
COMBUSTION & VENTILATION AIR....	6	TROUBLE SHOOTING CHART.....	11,12
CLEARANCES.....	7	BLOWER INSTRUCTIONS.....	13
DRAFT DIVERTER.....	7	TSK WALL STAT KIT.....	14
DOOR KNOB.....	7	PARTS DRAWING.....	15
PILOT ADJUSTMENT.....	8	PARTS PRICE LIST.....	16
		WARRANTY.....	18

**The State of Massachusetts requires that installation and service of a gas appliance be performed by a plumber or gas fitter licensed in the Commonwealth of Massachusetts.**

### READ CAREFULLY BEFORE INSTALLING UNIT

These installation instructions are a general guide and do not supersede applicable local codes and ordinances. Before planning or making the installation be sure it complies with all phases of the local heating code. (Or, in the absence of local codes, with the latest edition of National Fuel Gas Code, ANSI.Z223.1, or CAN1-B149).

The appliance, when installed, must be electrically grounded in accordance with local codes, or in the absence of local codes, with the latest edition of National Electrical Code ANSI/NFPA 70, or Canadian Electrical Code CSA-C22.1.

All of the ANSI and NFPA standards referred to in these installation instructions are the ones that were applicable at the time the design of this appliance was certified. The ANSI standards are available from the American Gas Association, 1515 Wilson Blvd., Arlington, VA. 22209.

The NFPA standards are available from the national Fire Protection Association, 60 Batterymarch Street, Boston, Massachusetts 02110.

Canadian standards are available from International Approval Services, 178 Rexdale Boulevard, Etobicoke, Ontario, Canada M9W 1R3.

The design of this appliance was certified to comply with ANSI Z21.11.1 vented room heaters and CAN1-2.1-M86.

Installer must leave these instructions with the consumer, have them complete, and return the warranty card.

### ROOM HEATER SPECIFICATIONS

Your room heater comes packed in a single carton. Before installation, check the rating plate to verify that the Model Number is correct and that the room heater is equipped for the type gas you intend to use.

#### SPECIFICATIONS

TYPE	CONTROL	GAS	MODEL NUMBERS			
CLOSED FRONT	THERMOSTAT BULB	NATURAL	VC201A-H	VC351A-H	VC501A-H	VC701A-H
CLOSED FRONT	THERMOSTAT BULB	L.P.	VC202A-H	VC352A-H	VC502A-H	VC702A-H
RADIANT FRONT	THERMOSTAT BULB	NATURAL	N/A	VCR351A-H	VCR501A-H	VCR701A-H
RADIANT FRONT	THERMOSTAT BULB	L.P.	N/A	VCR352A-H	VCR502A-H	VCR702A-H
HEIGHT			20"	26"	26"	30"
WIDTH			24"	30"	30"	36"
DEPTH			15-1/4"	15-1/4"	19-1/4"	19-1/4"
INPUT (BTU/HR.)			20,000	35,000	50,000	70,000
GAS INLET/OUTLET SIZE			1/2X3/8"	1/2X3/8"	1/2X3/8"	1/2X3/8"
VENT SIZE			3"	4"	4"	5"
CENTER OF VENT TO FLOOR			16-1/2"	21-1/2"	21-1/2"	25-1/2"
NUMBER OF RADIANTS ("VCR" SERIES)			N/A	5	5	5
NUMBER OF RADIANT GLASS ("VCR" SERIES)			N/A	2	2	2
APPROX. SHIPPING WEIGHT ("VC" SERIES)			55 LBS.	84 LBS.	112 LBS.	138 LBS.
APPROX. SHIPPING WEIGHT ("VCR" SERIES)			N/A	96 LBS.	124 LBS.	150 LBS.
*OPTIONAL BLOWER MODEL			N/A	CHB-3	CHB-3	CHB-3

\*Blowers also available factory mounted on 50M Btu units. All 70M Btu units come with blower mounted only.

## INTRODUCTION

THIS IS A GAS-FIRED, GRAVITY VENTED ROOM HEATER THAT WILL OPERATE SAFELY AND PROVIDE AN EFFICIENT SOURCE OF HEAT WHEN INSTALLED, OPERATED AND MAINTAINED AS RECOMMENDED IN THESE INSTALLATION AND OPERATING INSTRUCTIONS. READ THESE INSTRUCTIONS THOROUGHLY BEFORE INSTALLING, SERVICING, OR USING THIS APPLIANCE. IF YOU DO NOT UNDERSTAND ANY PART OF THESE INSTRUCTIONS, CONSULT LOCAL AUTHORITIES, OTHER QUALIFIED INSTALLERS, SERVICE AGENCIES, THE GAS SUPPLIER, OR THE MANUFACTURER.

## VENTING

This heater must be connected to a properly installed and maintained venting system. This heater is equipped with a vent safety shut-off device. Pilot outage will occur if the heater is not connected to a vent system. Pilot outage may occur due to restriction or blockage in the vent or if connected to a masonry chimney having an area greater than the vent size shown on Page 2.

This appliance should be vented through a properly sized listed type B vent that has been constructed in accordance with the National Building Code. If a horizontal section of vent is used, it must slope upwards a minimum of ¼ inch per foot of length.

This heater must not be connected to a vent system being used for wood or coal burning appliances. The use of more than one appliance per vent system will most likely cause the vent safety shut-off device to shut off the heater due to the cooling of vent temperatures through the draft diverter of the second appliance. In some situations, the vent safety shut-off may shut down the heater if a too large, unlined, masonry chimney is used. Due to low vent temperatures associated with more efficient heaters it may take too long to get the vent action going in a chimney before the shut-off device will shut down the heater. If this is the case, we recommend lining the chimney with the proper size type B vent pipe or type B chimney liner.

**WARNING:** Do not bypass the vent safety shutoff switch. To do so could expose the consumer to property damage, personal injury or possible death.

The switch, when activated, will extinguish the pilot flame. If the homeowner experiences this problem, the vent system must be checked and corrected. NOTE: An existing vent that has worked for years may not be adequate for today's design because of higher efficiency requirements resulting in lower stack temperatures. The following is a list of possible causes and corrective actions.

<u>POSSIBLE CAUSES</u>	<u>CORRECTIVE ACTION</u>
1. Blockage in vent pipe	1.A) Check vent pipe for blockage, such as bird nest, wasp nest, twigs, leaves, etc. 1.B) Check that the vent cap is properly installed, not shoved too far down on the vent pipe.
2. Burner is over firing	2.A) Check the manifold pressure. 2.B) Check the rate, NOTE: This appliance was orificed for elevations up to 2,000 feet. When installed at higher elevations refer to orifice chart in main burner orifice section of instructions for proper orifice size and re-orifice accordingly.
3. Improper vent system	3. Correct vent system.
A) Vent too short	A) The vent should not terminate less than 5 feet above the draft hood connection. A gas vent extending through an exterior wall shall not terminate adjacent to the wall or below eaves or parapets. Also, the top of the vent must be at least 2 feet above any obstacles within a 10 foot radius, including the roof. See Figure A.
B) Restriction in vent system caused by offsets	B) All type "B" vent shall extend in a generally vertical direction with offsets not exceeding 45 degrees, except that a vent system having not more than one 60 degree offset may be allowed. Any angle greater than 45 degrees from the vertical is considered horizontal. The total horizontal run of a vent plus the horizontal vent connector shall be not greater than 75 percent of the vertical height of the vent. Any offsets used should be as far above the draft hood as possible to allow a venting action to begin before any restriction is encountered.
C) Incorrect vent pipe	C) Use listed "B" type vent pipe. Do not use transite or any other type of ceramic pipe for venting. Do not use single wall pipe.
4. Loose connections on the vent safety wiring harness	4. Check the connection on both the switch and the gas valve. Tighten if necessary.

## VENTING

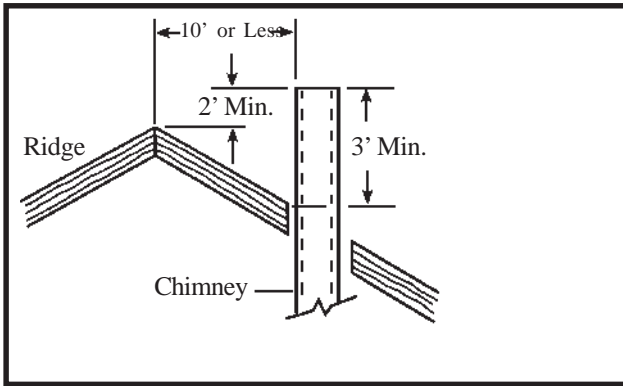

FIGURE A

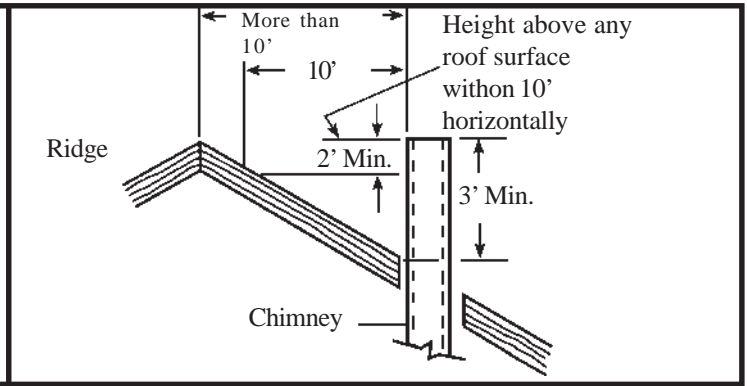
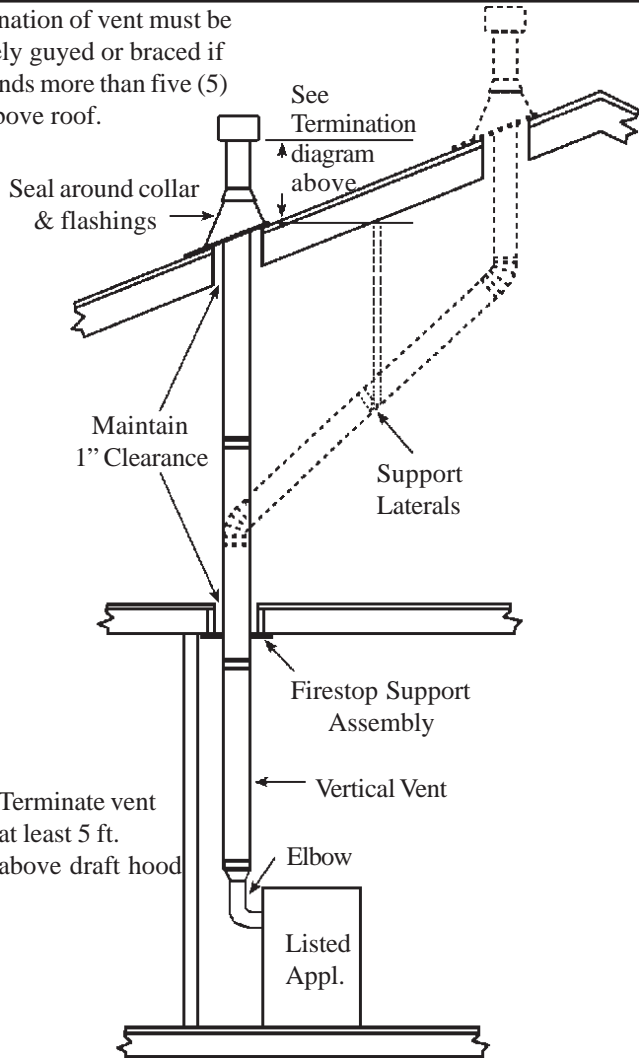

FIGURE A

Termination of vent must be securely guyed or braced if it extends more than five (5) feet above roof.



### CONNECTING THE VENT INTO AN EXISTING CHIMNEY

#### **SAFE (See "Venting")**

NOTE: This may result in the vent safety switch shutting down the pilot depending on size and draw of chimney.

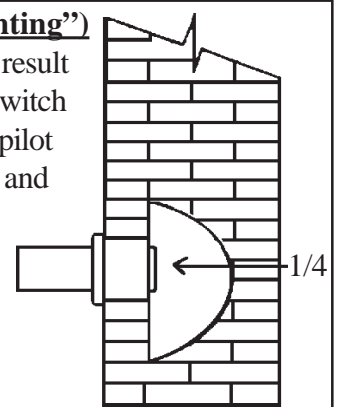

FIGURE 7A

#### **UNSAFE**

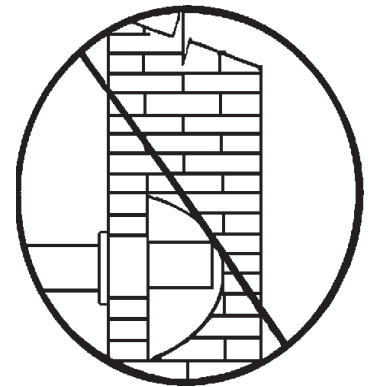

FIGURE 7B

#### **RECOMMENDED**

Use proper size "B" pipe or chimney liner inside chimney.

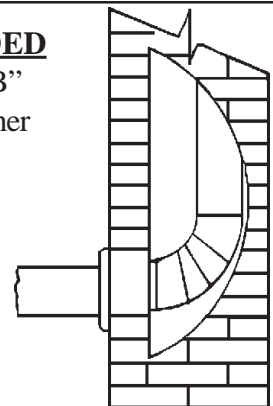

FIGURE 7C

## GAS SUPPLY

This vented room heater must be connected to a gas supply capable of supplying the appliances full rated capacity. Provide a 1/8 inch N.P.T. plugged tapping, accessible for test gauge connection, immediately upstream of the gas supply connection to the appliance. The minimum inlet pressure in the gas supply pipe should be 4.5" w.c. for Natural Gas and 11.0" w.c. for Propane Gas, "for the purpose of input adjustment". The maximum inlet pressure in the gas supply pipe should never exceed 14" w.c. for either Natural or Propane Gas. The gas supply piping should be sized in accordance with ANSI Z223.1 National Fuel Gas Code. The normal manifold pressure should be 3.5" w.c. for Natural Gas and 10.0" w.c. for Propane Gas.

If the outlet pressure of the gas valve must be adjusted, this should be done by a qualified serviceman using proper tools and instruments.

Check all connections with soapy water for possible gas leaks. Never use a match, candle or other ignition source. It is recommended that pipe compound which is resistant to the action of liquefied petroleum gases be used. Do not use Teflon tape or Teflon impregnated compound.

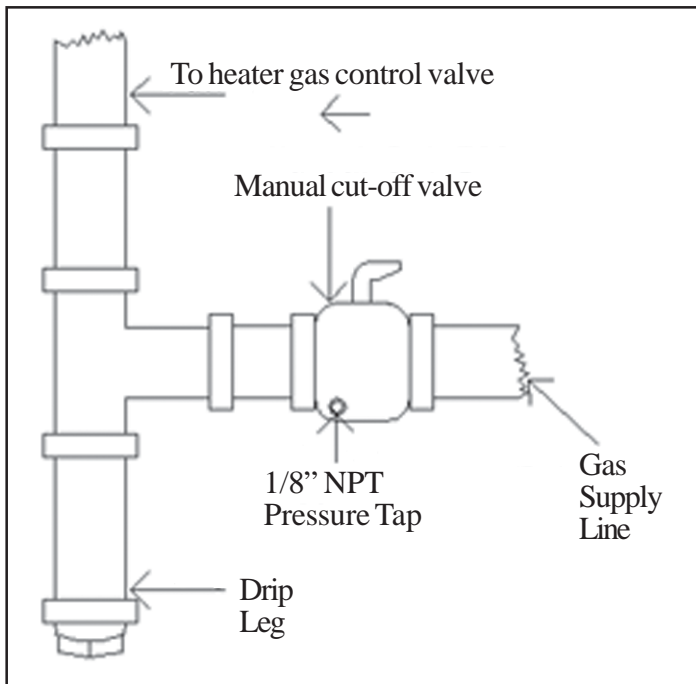

GAS SUPPLY

## GAS SUPPLY - Cont'd.

The appliance and its individual shutoff valve must be disconnected from the gas supply piping during any pressure testing of that system at the test pressure in excess of 1/2 psig.

The appliance must be isolated from the gas supply piping by closing its individual manual shutoff valve during any pressure testing of the gas supply piping system at test pressures equal to or less than 1/2 psig.

### LOCATION AND SPECIAL PRECAUTIONS

Due to high temperatures the appliance should be located out of traffic and away from furniture and draperies.

Children and adults should be alerted to the hazards of high surface temperature and should stay away to avoid burns or clothing ignition.

Young children should be carefully supervised when they are in the same room as the appliance.

Clothing or other flammable material should not be placed on or near the appliance.

Any safety screen, guard, or casing top removed for servicing a room heater must be replaced prior to operating the appliance.

Do not use this heater if any part has been under water. Immediately call a qualified service technician to inspect the heater and to replace any part of the control system and any gas control which has been under water.

For purpose of identifying the sides of the heater. When you are facing the front of the heater the right side has the access door and the left side is solid.

If heater is installed in a residential garage, all burners and pilot must be above 18". Locate or protect heater so it cannot be damaged by a moving vehicle.

## COMBUSTION AND VENTILATION AIR

When installed, this gas appliance must be provided with fresh air for combustion, ventilation, and dilution of hot flue gases. The minimum required volume of the area where the appliance is installed should be 50 cubic feet per 1,000 btu/hr.

If installed in an area of the home that is considered an unconfined space, the natural infiltration of air around windows and doors will be adequate. If the area is considered a confined space (less than 50 cubic feet per thousand btu), fresh air can be supplied by providing two permanent openings into adjoining rooms. Each opening shall have a minimum free area of one square inch per 1,000 btu per hour of the total input rating of all gas appliances in the confined space, but not less than 100 square inches. One of the openings shall be within 12 inches of the ceiling and one within 12 inches of the floor. See Figure A.

If the home is of unusually tight construction (new and remodeled homes), free air must be supplied through opening(s) to the outdoors. This can be accomplished by providing 2 permanent openings, one commencing within 12 inches of the ceiling and one within 12 inches of the floor. These openings shall communicate directly with the outdoors, or spaces that communicate freely with the outdoors, such as a ventilated attic and crawl space through galvanized or equivalent corrosion-resistant ducts. Exception: unobstructed stud and joist spaces are acceptable ducts provided that not more than one fire block is removed. Special provisions must be taken to insure that these stud and joist spaces cannot be blocked with insulation or other objects. Each of these openings using vertical ducts shall have a minimum free area of one square inch per 4,000 btu/hr of total input rating of all gas appliances. See Figure B and C. If horizontal ducts are used, the minimum free area shall be one square inch per 2,000 btu/hr of total input rating of all gas appliances.

Fresh make-up air can also be provided through a duct to one permanent opening commencing within 12 inches of the ceiling. The minimum free area of this opening shall be one square inch per 3,000 btu/hr of the total input rating of all gas appliances but not less than the sum of the areas of all vent connectors in the space. See Figure D.

When calculating the amount of fresh air needed you must include make-up air requirements for the operation of exhaust fans, kitchen ventilation systems, clothes dryers, and fireplaces.

Additional information can be found in the latest edition of ANSI Z223.1 (National Fuel Gas Code).

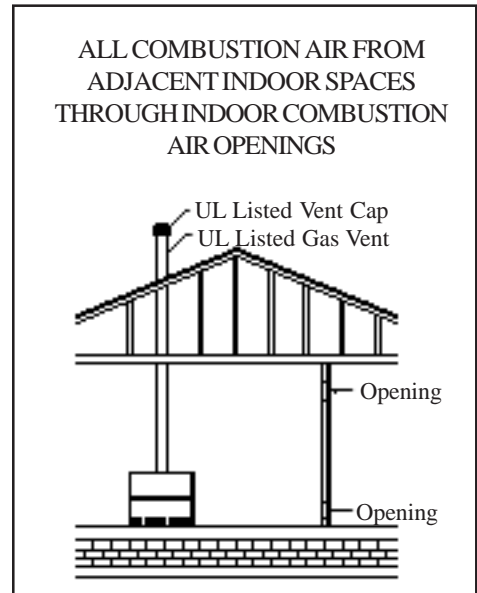

FIGURE A

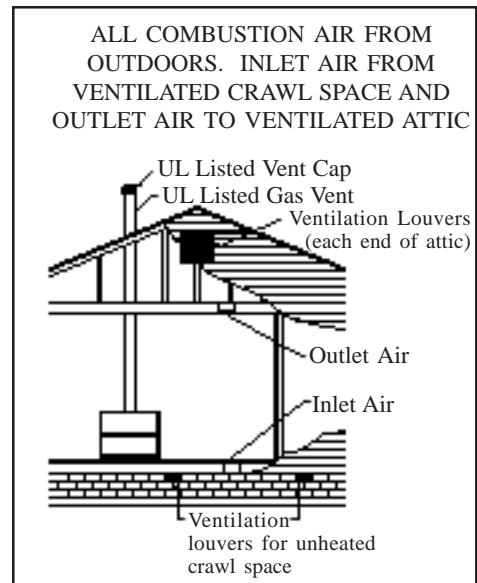

FIGURE B

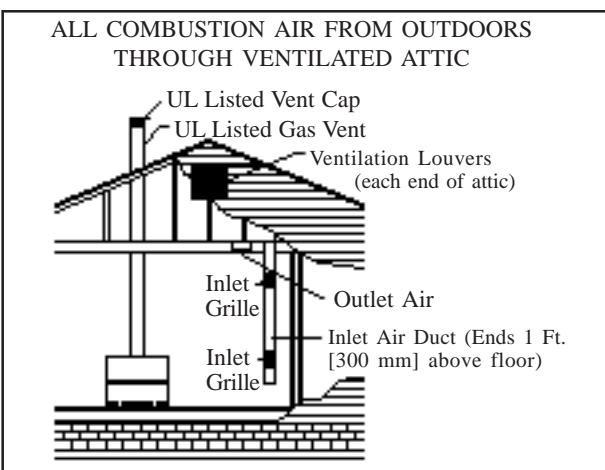

FIGURE C

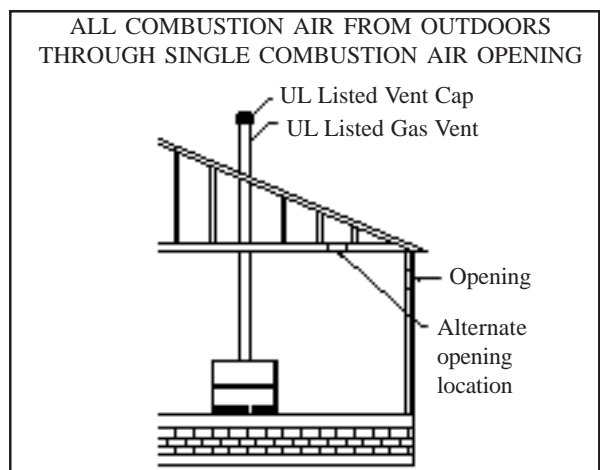

FIGURE D

## DRAFT DIVERTER

The draft diverter must be installed in the same atmospheric pressure zone as the combustion air supply for the main burner.

## DOOR KNOB

Remove from the inside of the casing door and assemble to the outside of the door. VC201 and VC202 have finger holes in the door in lieu of knob.

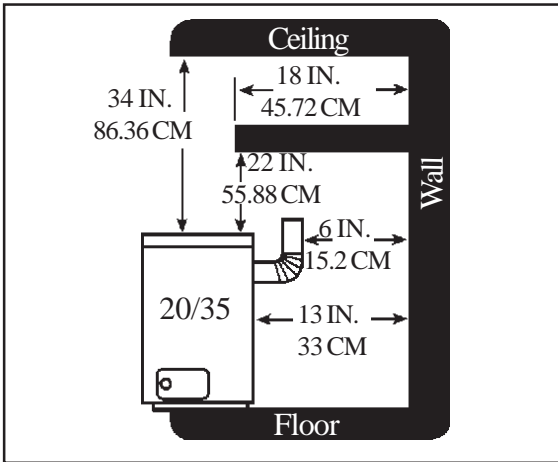

CLEARANCES - VC20, VC35, VCR35

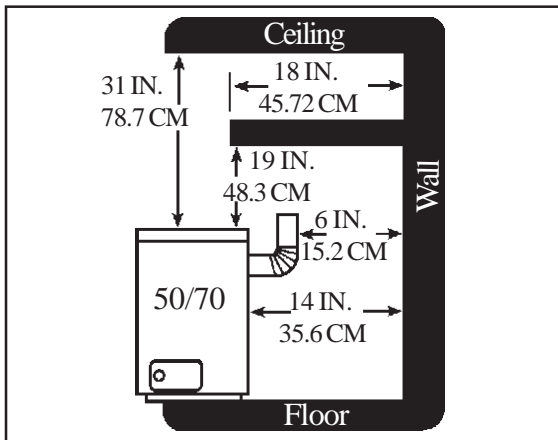

CLEARANCES - VC50 & VC70,  
VCR50 & VCR70

## WIRING DIAGRAM

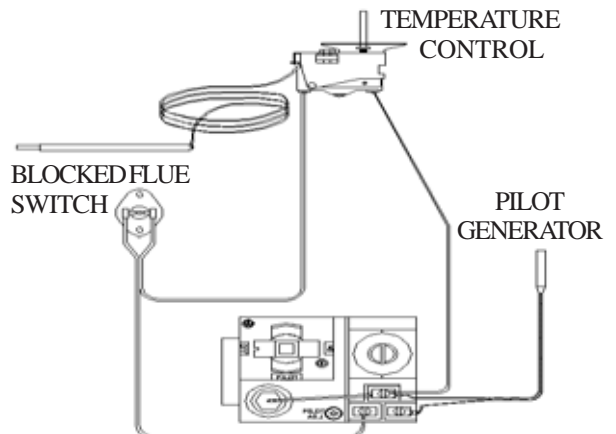

## CLEARANCES

If the area where the appliance is to be installed contains carpeting, tile, or combustible materials, other than wood flooring, the appliance shall be installed on a metal plate (stoveboard), a wood panel, or other non-combustible materials. The use of ceramic or quarry tile is acceptable and provides an appealing surface that is easily cleaned. This material is to extend 2 inches from each side and 12 inches from the front. It is advisable to extend this to the wall behind the appliance.

Clearances to combustibles are as follows:



- From jacket to adjacent side walls, 2" on the 20/35, and 6" on the 50/70. Maintain adequate clearance on right side for accessibility.
- From rear surface vertical vent pipe to rear walls – 6".
- From rear of unit to rear wall, 13" on 20/35, and 14" on the 50/70.
- From top of heater to ceiling, 34" on the 20/35, and 31" on the 50/70.
- From top of heater to any overhanging projections such as a mantle or window sill is 22" on the 20/35, and 19 inches on the 50/70 models, with a maximum horizontal extension of 18 inches.

The clearances around the air opening into the combustion chamber must be maintained, and the burner must be kept clean.

Do not permit dust or dirt to accumulate here. The other clearances previously mentioned must be maintained.

There must be adequate room provided and maintained around the heater for accessibility and for the flow of combustion and ventilation air.

## PILOT ADJUSTMENT

The pilot flame can be observed by opening the pilot lighting hole cover. The pilot flame should surround the top 3/8 to 1/2 inch of the thermocouple (see Figure 2). If the flame needs adjusting, first locate the pilot adjustment screw cap and remove. Adjustment screw is underneath (see Figure 1). To increase the flame, turn the pilot adjustment screw counterclockwise . To decrease the flame, turn the screw clockwise . NOTE: The pilot is unregulated. If incoming line pressure is more than 7" w.c. Natural Gas or 11" w.c. for L.P. Gas, the pilot flame size should be decreased.

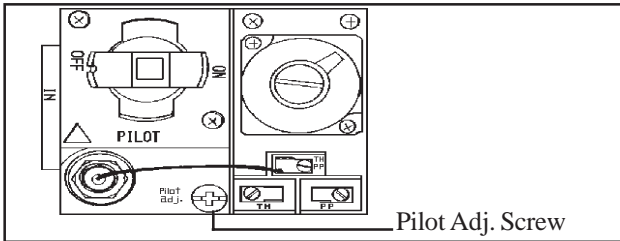

FIGURE 1

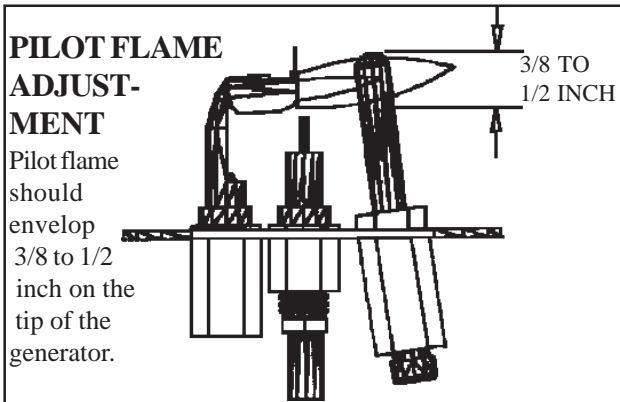

FIGURE 2

## RADIANTS AND GLASS PANELS FOR ALL VCR MODELS

(See Figure 9 – Replacement Parts Section)

### INSTALL GLASS AND RADIANTS AS FOLLOWS:

- STEP 1.** Remove three screws from under top of opening in bezel frame assembly.  
**STEP 2.** Pull top of bezel down and lay aside.  
**STEP 3.** Remove glass from bottom pad in shipping carton.  
**STEP 4.** Remove carton containing radiants from cavity of combustion chamber.  
**STEP 5.** Remove radiants from carton and install by tilting backwards and lifting at the same time into opening. Place the radiants on the burner radiants supports. The radiants must be straight. Never operate heater if any radiant is tilted to front or rear.

Continued

## MAIN BURNER ORIFICE

This appliance was shipped from the factory with an orifice sized to give the correct gas input using the gas for which the heater was equipped. There may be local conditions, such as variation in gas pressure or BTU content of the gas, which may be cause for a change in the orifice. The gas company supplying the fuel or the installing contractor should check the gas input rate.

If the rate exceeds the "BTUH INPUT" on the rating plate by 5%, the orifice should be replaced with a smaller orifice by a qualified technician to reduce the input to the rating plate value.

The input rate may need to be adjusted for elevation. See the following charts to determine the correct orifice size for your Model Number and elevation. These orifice sizes are based on a heating value of 1020 for Natural Gas and 2500 for L.P. Gas.

**CAUTION:** As elevation increases, derating is necessary for the safe and proper operation of this heater. Do not increase the Btu input rate by increasing the orifice size or gas pressure. Allow for elevation derating when sizing gas heating equipment.

### NATURAL GAS

SPECIFIC ELEVATIONS						
Model No.	0 to 2,000'	2,000- 4,000'	4,000 - 6,000'	6,000 - 8,000'	8,000' - 10,000'	
VC201	45	47	48	49	50	50
VC351	35	37	38	40	42	42
VC501	30	31	31	32	35	35
VC701	25	27	28	29	30	30
VCR351	35	37	38	40	42	42
VCR501	30	31	31	32	35	35
VCR701	25	27	28	29	30	30
ORDER KIT #49820 45-1 HIGH ALTITUDE KIT						

### L.P. GAS

SPECIFIC ELEVATIONS						
Model No.	0 to 2,000'	2,000- 4,000'	4,000 - 6,000'	6,000 - 8,000'	8,000' - 10,000'	
VC202	1.3mm	55	56	56	57	57
VC352	1.65mm	53	53	54	54	54
VC502	47	49	49	50	51	51
VC702	41	42	43	44	46	46
VCR352	1.65mm	53	53	54	54	54
VCR502	47	49	49	50	51	51
VCR702	41	42	43	44	46	46
ORDER KIT #49820 45-1 HIGH ALTITUDE KIT						

- STEP 6.** Install glass panels by inserting top edge into upper retainer and lower into bottom support, and slide glass into position. Do not allow a crack between the two glass panels. Never operate heater with either glass missing or cracked.  
**STEP 7.** Re-install bezel by placing bezel tabs over lower front and swing bezel into position and secure with three screws.

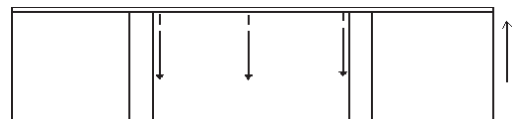

CAUTION: There may be momentary and spasmodic orange flashes in the flame. This is caused by the burning of air borne dust particles and is not to be confused with the yellow tipping which is a stable or permanent situation when there is insufficient primary air.

## MAINTENANCE

**CLEANING:** To clean the front casing of your heater, it is only necessary to use a soft cloth. Light dust can be removed in this way. To obtain a polish or gloss, use a little light machine oil on the cloth. Do not use metal polish or cleaning solution. The burner ports should be kept free from lint and dust.

### CLEANING OF COMBUSTION CHAMBER

The combustion chamber of your console heater should never need to be cleaned if proper burner adjustment and gas pressures are maintained. However, if an unusual circumstance should occur, the following procedure should be followed in cleaning your combustion chamber.

1. Turn off gas supply to heater at manual valve in supply line to heater.
2. Disconnect heater at ground joint union ahead of main gas valve.
3. Remove main control and orifice assembly.
4. Remove burner.
5. Remove combustion chamber.
6. Using a scraper, scrape inside of a primary combustion chamber. This should be area of heaviest accumulation of carbon.
7. Remove plug bottom located in bottom rear of second combustion chamber. Using a bottlebrush, clean inside of this chamber. Shake residue out the clean-out hole.
8. Clean the rear chamber by using bottlebrush through the vent tube openings.
9. Replace combustion chamber, burner and control. Check all gas piping for leaks before lighting heater.

Repair service should be performed by qualified persons. The heater should be inspected before initial use. An annual cleaning of control compartment and safety performance check should be made by a qualified service person. More frequent cleaning may be required when exposed to the excessive lint conditions due to carpeting and bedding material, etc. It is imperative that the control compartment, burners, and circulating air passageways of the heater be kept clean. Any safety screen, casing top, or guard removed for servicing the heater must be replaced prior to operating heater.

If the venting system is not maintained in proper operating condition, the vent safety shutoff will not allow heater to operate. Periodic examination of the entire venting system as a routine part of the safety performance check is recommended on an annual basis.

It is advised that the pilot and main burner flames be checked at least twice during the heating season for any changes in flame characteristics. See Figure 2 and Figure 3.

PROPER BURNER FLAME

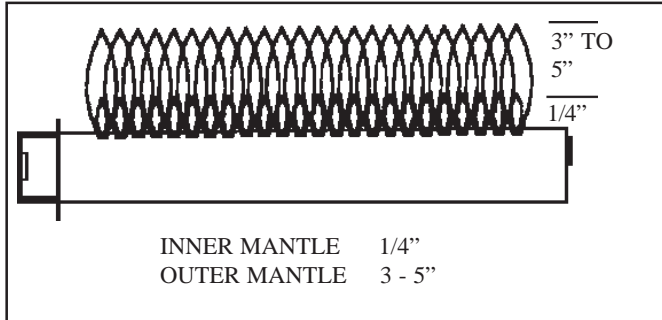

FIGURE 3

### SERVICE RECORD

SERVICE RECORD	

THIS IS A GAS-FIRED APPLIANCE, KEEP THE AREA CLEAR OF GASOLINE AND OTHER FLAMMABLE VAPORS AND LIQUIDS. ALL COMBUSTIBLE MATERIAL MUST BE KEPT CLEAR OF THIS AREA.

HAVE A QUALIFIED SERVICEMAN CHECK THE BURNER PERIODICALLY. REMOVE AND CLEAN IF NECESSARY.

**MODELS:** VC201A-H, VC202A-H, VC351A-H, VC352A-H, VC501A-H, VC502A-H, VC701A-H, VC702A-H, VCR351A-H, VCR352A-H, VCR501A-H, VCR502A-H, VCR701A-H, VCR702A-H

## FOR YOUR SAFETY READ BEFORE LIGHTING

**WARNING: If you do not follow these instructions exactly, a fire or explosion may result causing property damage, personal injury or loss of life.**

- A. This appliance has a pilot which must be lighted by hand. When lighting the pilot, follow these instructions exactly.
- B. **BEFORE LIGHTING** smell all around the appliance area for gas. Be sure to smell next to the floor because some gas is heavier than air and will settle on the floor.
- WHAT TO DO IF YOU SMELL GAS:**
- Do not try to light any appliance.
  - Do not touch any electric switch; do not use any phone in your building.
  - Immediately call your gas supplier from a neighbor's phone. Follow the gas supplier's instructions.
  - If you cannot reach your gas supplier, call the fire department.
- C. Use only your hand to push in or turn the gas control knob. Never use tools. If the knob will not push in or turn by hand, don't try to repair it, call a qualified service technician. Force or attempted repair may result in a fire or explosion.
- D. Do not use this appliance if any part has been under water. Immediately call a qualified service technician to inspect the appliance and to replace any part of the control system and any gas control which has been under water.

## LIGHTING INSTRUCTIONS

1. **STOP!** Read the information on the safety label.
2. Turn temperature control knob to "OFF" or it's lowest position.
3. Depress and turn gas control knob clockwise to "OFF" position.

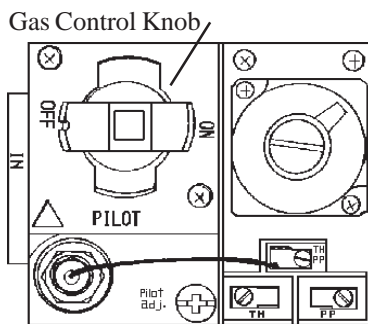

NOTE: Knob can not be turned from "PILOT" to "OFF" unless knob is pushed in slightly. Do not force.

Pilot is located on end of combustion chamber above burner.

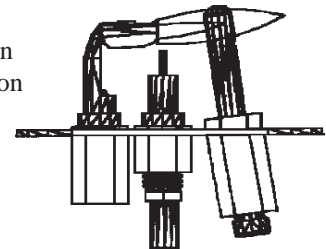

4. Wait five (5) minutes to clear out any gas. Then smell for gas, including near the floor. If you smell gas, **STOP!** Follow "B" in the information on the safety label. If you don't smell gas, go to the next step.
5. Open casing door and pilot lighting hole cover.
6. Find pilot. (Follow metal pilot tube from gas control).
7. Locate red piezo ignitor button on top of heater.
8. Turn gas control knob counterclockwise to "PILOT".
9. Push in gas control knob and hold in. Immediately begin a series of pushing and releasing the red piezo ignitor button, while observing the pilot. Continue to spark until pilot is lit. Continue to hold the gas control knob in for about one (1) minute after the pilot is lit. Release the gas control knob and it will pop back up. Pilot should remain lit. If pilot goes out, repeat steps 3 thru 9.
10. Close pilot lighting hole cover and casing door.
11. Turn gas control knob counterclockwise to "ON".
12. Turn temperature control knob to desired setting.

## TO TURN OFF GAS TO APPLIANCE

1. Turn the temperature control knob to it's lowest setting.
2. Push in gas control knob slightly and turn clockwise to "OFF". Do not force.

## TROUBLE SHOOTING CHART for qualified serviceman - MAIN BURNER

SYMPTOM	POSSIBLE CAUSES	CORRECTIVE ACTION
Flame too large	<ol style="list-style-type: none"> <li>1. Defective operator section of gas valve.</li> <li>2. Burner orifice too large.</li> <li>3. Pressure regulator malfunction.</li> </ol>	<ol style="list-style-type: none"> <li>1. Replace complete valve.</li> <li>2. See orifice chart to determine the correct orifice size for your Model Number and elevation.</li> <li>3. Regulator must be adjusted by a qualified serviceman using proper tools and instruments.</li> </ol>
Noisy Flame	<ol style="list-style-type: none"> <li>1. Noisy pilot.</li> <li>2. Burr in orifice (if it whistles or resonates).</li> <li>3. Excessive gas input.</li> </ol>	<ol style="list-style-type: none"> <li>1. Reduce pilot gas with adjusting screw on combination gas. (Fig. 1).</li> <li>2. Remove burr or replace orifice (Do not enlarge orifice).</li> <li>3. See "Flame Too Large", above.</li> </ol>
Yellow tip flames (Some yellow tipping on LP Gas is permissible)	<ol style="list-style-type: none"> <li>1. Clogged main burner ports.</li> <li>2. Clogged draft hood.</li> <li>3. Linted up air shutter.</li> </ol>	<ol style="list-style-type: none"> <li>1. Clean main burner ports (Do not enlarge ports).</li> <li>2. Clean draft hood.</li> <li>3. Check for dust or lint at air mixer opening and around the shutter.</li> </ol>
Floating Flame	<ol style="list-style-type: none"> <li>1. Blocked venting.</li> </ol>	<ol style="list-style-type: none"> <li>1. Clean flue passageways to relieve blockage.</li> </ol>
Gas Odor	<ol style="list-style-type: none"> <li>1. Chimney or flue obstruction.</li> <li>2. Drafts around heater.</li> <li>3. Gas leak.</li> </ol>	<ol style="list-style-type: none"> <li>1. Clean flue.</li> <li>2. Eliminate drafts.</li> <li>3. Shut off gas service immediately. Check piping. Call gas company. See "For Your Safety" (Page 1), and "Gas Supply" (Page 3).</li> </ol>
Delayed Ignition	<ol style="list-style-type: none"> <li>1. Pilot flame too small.</li> <li>2. Burner ports clogged near pilot.</li> <li>3. Low gas pressure.</li> <li>4. Pilot decreases in size when main burners come on.</li> <li>5. Drafts around unit.</li> <li>6. Pilot lighter door open causing disturbance of pilot flame.</li> <li>7. Improper venting.</li> <li>8. Pressure regulator malfunction.</li> </ol>	<ol style="list-style-type: none"> <li>1. Check pilot orifice, clean, increase pilot gas flow if necessary by adjusting at combination control valve (Fig. 1).</li> <li>2. Clean burner ports (do not enlarge ports).</li> <li>3. Check gas supply pressure. See "Gas Supply".</li> <li>4. Supply piping is inadequately sized. Consult local gas utility or competent installer.</li> <li>5. Eliminate drafts.</li> <li>6. Close pilot lighter door.</li> <li>7. See "Venting" (Page 2).</li> <li>8. Regulator must be adjusted by a qualified serviceman using proper tools and instruments.</li> </ol>
Failure to ignite	<ol style="list-style-type: none"> <li>1. Main gas off.</li> <li>2. Defective gas valve.</li> </ol>	<ol style="list-style-type: none"> <li>1. Open all manual gas valves.</li> <li>2. Replace gas valve.</li> </ol>
Condensation of water vapor.	<ol style="list-style-type: none"> <li>1. Improper venting.</li> </ol>	<ol style="list-style-type: none"> <li>1. See "Venting".</li> </ol>
Burner won't turn off	<ol style="list-style-type: none"> <li>1. Defective or sticking automatic valve.</li> <li>2. Excessive gas pressure (The supply gas pressure must not exceed 1/2 psi or 14" water column).</li> </ol>	<ol style="list-style-type: none"> <li>1. Clean or replace valve.</li> <li>2. To correct this situation contact the gas company supplying the gas. See "Gas Supply".</li> </ol>

## TROUBLE SHOOTING CHART - POOR HEATING RESULTS

Incorrect gas input	<ol style="list-style-type: none"> <li>1. Gas input not checked.</li> <li>2. Clogged orifice.</li> <li>3. Pressure regulator.</li> <li>4. Thermostat capillary tube damaged.</li> </ol>	<ol style="list-style-type: none"> <li>1. Re-check gas input. See "Gas Supply".</li> <li>2. Check orifices for clogging. If clogged, clean out the hole carefully with a smooth wood toothpick. (Do not in any way enlarge or distort it).</li> <li>3. Regulator must be adjusted by a qualified serviceman using proper tools and instruments.</li> <li>4. Replace gas valve.</li> </ol>
---------------------	---	---

## TROUBLE SHOOTING CHART - POOR HEATING RESULTS - Cont'd.

SYMPTOM	POSSIBLE CAUSES	CORRECTIVE ACTION
Not enough heat	<ol style="list-style-type: none"> <li>1. Heater undersized.</li> <li>2. Temperature dial set too low.</li> <li>3. Incorrect gas supply pressure.</li> </ol>	<ol style="list-style-type: none"> <li>1. This is especially true when a dwelling or room is enlarged. Have the heat loss calculated and compare to the heater output (70% of input). Your gas company or installer can supply you with this information. If heater is undersized, replace with correct size unit.</li> <li>2. Raise setting of temperature dial. See "Lighting and Shutting Down Instructions".</li> <li>3. Check gas supply pressure and regulator pressure as outlined above.</li> </ol>
Too much heat	<ol style="list-style-type: none"> <li>1. Temperature dial set too high.</li> <li>2. Combination control valve sticks open.</li> </ol>	<ol style="list-style-type: none"> <li>1. Lower setting of temperature dial. See "Lighting and Shutting Down Instructions".</li> <li>2. Replace combination control valve.</li> </ol>

## TROUBLE SHOOTING CHART - AUTOMATIC PILOT & VALVE

Burner won't light	<ol style="list-style-type: none"> <li>1. Pilot flame too large or too small.</li> <li>2. Defective combination control valve.</li> </ol>	<ol style="list-style-type: none"> <li>1. Re-adjust pilot flame using adjustment on combination control valves (See Fig. 1 &amp; 1A).</li> <li>2. Replace valve.</li> </ol>
Pilot outage	<ol style="list-style-type: none"> <li>1. Dirt in pilot orifice.</li> <li>2. Pilot lighter door open.</li> <li>3. Defective automatic pilot section in combination control valve.</li> <li>4. Defective thermocouple.</li> <li>5. Vent safety shut off system.</li> </ol>	<ol style="list-style-type: none"> <li>1. Clean pilot orifice with air or solvent, do not ream.</li> <li>2. Close pilot lighter door.</li> <li>3. Replace combination control valve.</li> <li>4. Replace thermocouple.</li> <li>5. See "Venting" section.</li> </ol>
Pilot will not stay lit when control knob is released	<ol style="list-style-type: none"> <li>1. Pilot flame too large or too small.</li> <li>2. Defective thermocouple.</li> <li>3. Defective gas valve.</li> <li>4. Loosen connections at spill switch or ECO on gas valve.</li> </ol>	<ol style="list-style-type: none"> <li>1. Re-adjust pilot flame using adjustment on combination control valves (See Fig. 1 &amp; 1A).</li> <li>2. Replace thermocouple.</li> <li>3. Replace gas valve.</li> <li>4. Tighten connections.</li> </ol>

## CHB-3 BLOWER INSTALLATION - (OPTIONAL) (STANDARD ON 70,000 BTU UNITS ONLY)

- STEP 1.** Run black wire and white wire that comes from bottom of junction box down through the heat shield. See Figure A.
- STEP 2.** Insert junction box into opening in back of heater. Attach using four #8x1/2" black screws provided. See Figure A.
- STEP 3.** Attach fan switch to fan switch bracket using two #8x1/2" plated, Phillip head screws provided. The 2" flange on the bottom of bracket and terminals on the fan switch should be toward the back of the heater when properly installed.
- STEP 4.** Locate the two engagement holes in base of heater. On a 35,000 Btu heater these holes are approximately 6-1/2" from the back edge and right and left holes are 5-1/4" and 7-1/4" respectfully from the right side (as viewed from back of heater). On a 50,000 Btu heater the holes are approximately 10-3/4" from the back edge and right and left holes are 5-3/8" and 7-3/8" respectfully from the right side. Attach fan switch bracket to base using two #8x1/2" hex head screws provided. This will require a 1/4" socket and ratchet. See Figure A.
- STEP 5.** Locate the blower opening and mounting tab on the base of the heater. Insert the front flange of the blower housing under the mounting tab, lower the back of the blower down onto the base aligning the clearance holes in the blower base with the engagement holes in the heater base. Secure the blower to the base with two #8 screws provided. See figure A.
- STEP 6.** Connect black wire from junction box to right fan switch terminal. See Figure B.
- STEP 7.** Connect white wire from junction box to white fan motor wire. See Figure B.
- STEP 8.** Connect black wire from fan motor to left fan switch terminal. See Figure B.
- STEP 9.** Turn variable speed control switch clockwise ↻ (as viewed from front of unit) to "OFF".
- STEP 10.** Plug power cord into 115 V. grounded receptacle.
- STEP 11.** Turn variable speed control switch counterclockwise ↶ (as viewed from front of unit) from "OFF" to "HIGH". Blower will now cycle on automatically when the switch temperature is met after the main burner comes on. The blower will continue to run for a short period after the main burner goes off. Blower speed can be adjusted by setting the variable speed control switch between high and low.

**WARNING:** This appliance is equipped with a three-prong (grounding) plug for your protection against shock hazard and should be plugged directly into a properly grounded three-prong receptacle. Do not cut or remove the grounding prong from this plug.

**CAUTION:** Label all wires prior to disconnection when servicing controls. Wiring errors can cause improper and dangerous operation. Verify proper operation after servicing.

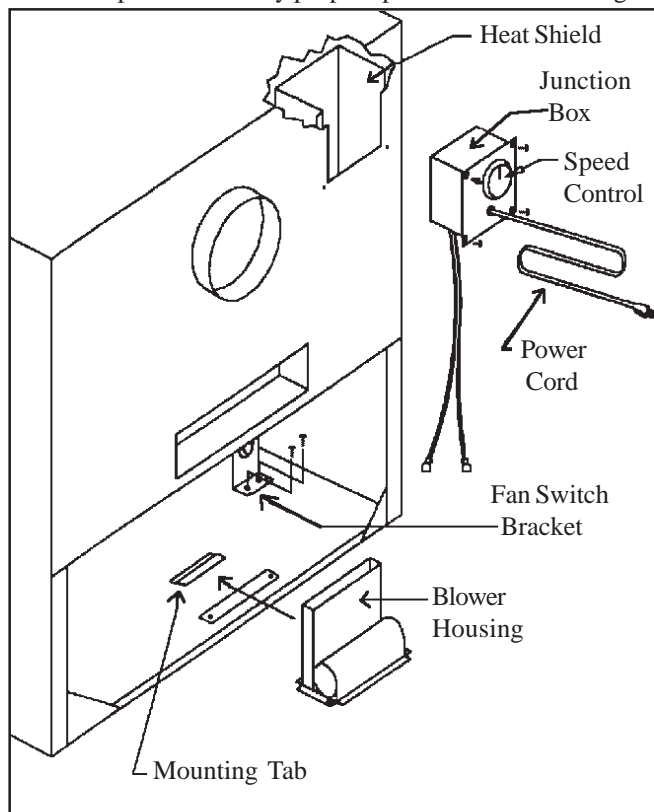

FIGURE A

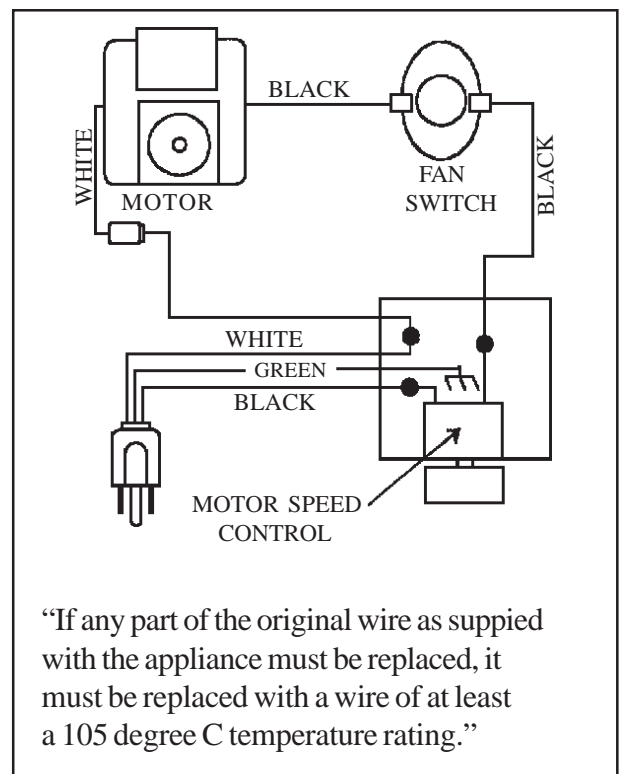

FIGURE B

# TSK WALL STAT KIT OPTIONAL

## (VC/VCR-H SERIES HEATERS)

### WALL THERMOSTAT INSTALLATION INSTRUCTIONS

Your heater can be re-wired to operate with a millivolt wall thermostat by your installer. See wiring diagram below for correct wiring.

NOTE: Do not disconnect the wire from the blocked flue switch to the "TH" terminal on the gas valve.

- STEP 1. Turn temperature control knob to "OFF" or lowest setting.
- STEP 2. Turn gas valve control knob to "OFF".
- STEP 3. Disconnect wire leading from **Part #70080** (Bulb Control Switch) from valve.
- STEP 4. Cut the remaining wire leading from **Part #70080** (Bulb Control Switch) to the blocked flue switch, leaving its end connected to the blocked flue switch and leaving enough length to reach the gas valve. Strip 1/2" of the insulation from the cut end of the wire.
- STEP 5. Connect one leg of thermostat wire to the "TH/PP" terminal on the gas valve.
- STEP 6. Connect second leg from the thermostat to the stripped wire coming from the blocked flue switch. Secure this connection inside the heater cabinet.
- STEP 7. Secure both red wires from blocked flue switch inside heater cabinet. Make sure none of the wires have enough slack to lay against the heat exchanger or draft hood.
- STEP 8. Remove lighting instructions P/N 91237, 91238, 91239 from back of heater and replace with P/N 91242, 91243, 91244 lighting instructions supplied in TSK Kit.
- STEP 9. Follow lighting instructions to place heater in operation.

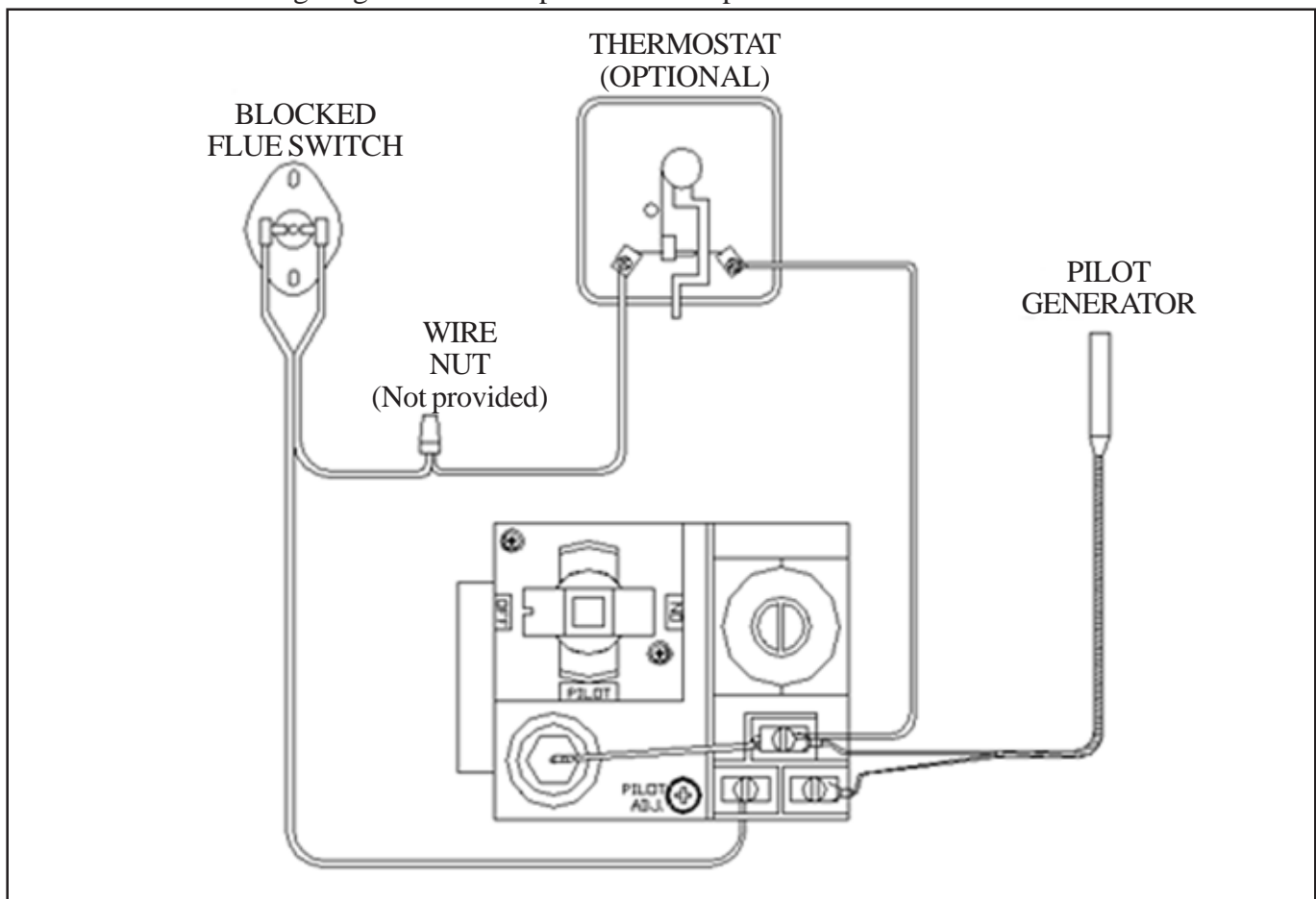

**MODELS INCLUDED:**

VC-H / Closed Front Circulators  
VCR-H / Radiant Front Circulators  
CHB3 Blower



**VENTED CONSOLE HEATER**

Prices and specifications subject to change without notice. All prices are F.O.B. factory.

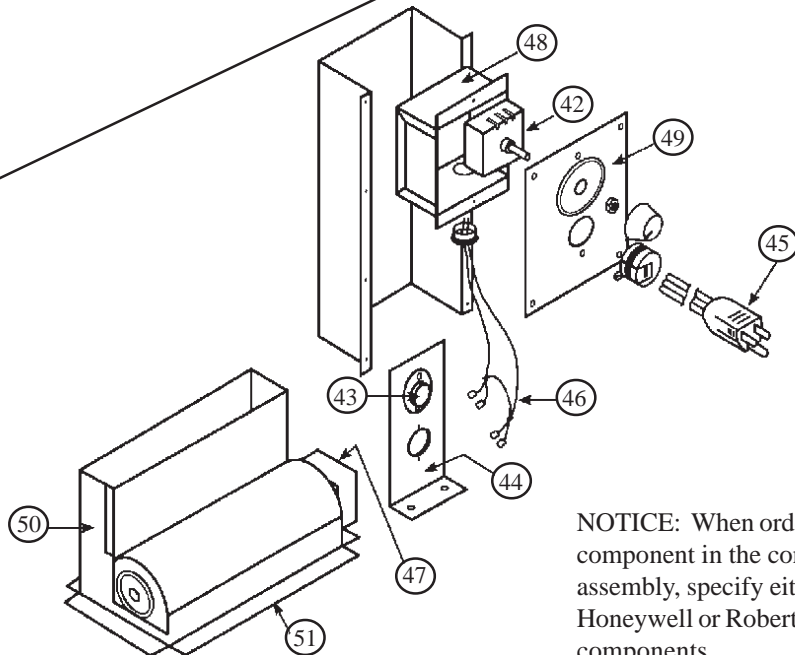
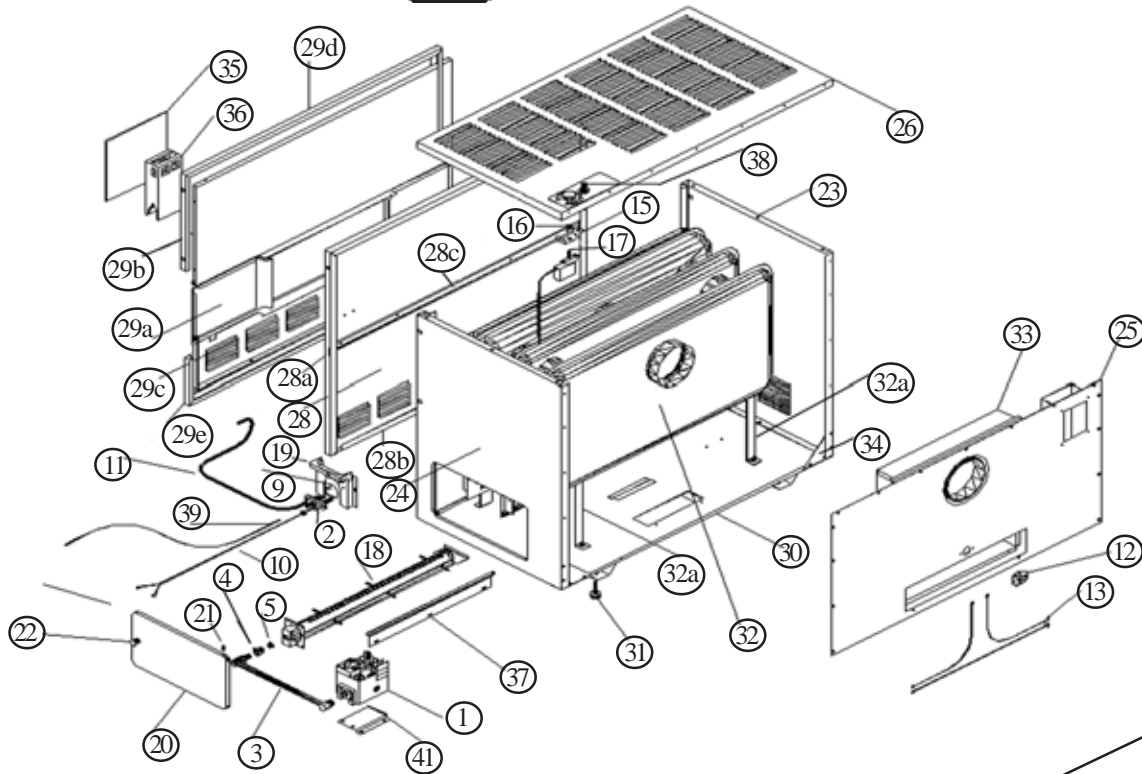

**Mr. Contractor**, we only sell parts through our wholesalers, but the prices listed are for your convenience. For prompt parts service, contact the wholesaler from which you purchased your Cozy heater. **NOTE:** Parts & schematic drawings on current models are shown at [www.cozyheaters.com](http://www.cozyheaters.com).

**NOTICE:** When ordering any component in the control train assembly, specify either Honeywell or Robertshaw components.

HOW TO PROPERLY ORDER PARTS: In addition to part description and part number, please give model number, and type of gas used. This information can be found on the rating plate that is attached to rear of heater.

MODEL NUMBER	NAT.	VC201A-H		VC / VCR351-H		VC / VCR501A-H		VC / VCR701A-H	
	L.P.	VC202A-H		VC / VCR352-H		VC / VCR502A-H		VC / VCR702A-H	
PART DESCRIPTION	REF. NO.	PART NO.	LIST PRICE	PART NO.	LIST PRICE	PART NO.	LIST PRICE	PART NO.	LIST PRICE
Valve, VS821A1061 Honeywell, Nat. Gas	1	74315	\$ 182.90	74315	\$ 182.90	74315	\$ 182.90	74315	\$ 182.90
Valve, VS821A1418 Honeywell, L.P. Gas	1	74316	\$ 182.90	74316	\$ 182.90	74316	\$ 182.90	74316	\$ 182.90
Pilot Assy. 0.140.504 L.P.Gas	2	80063	\$ 25.40	80063	\$ 25.40	80063	\$ 25.40	80063	\$ 25.40
Pilot Assy. 0.140.514 Nat.Gas	2	80062	\$ 25.40	80062	\$ 25.40	80062	\$ 25.40	80062	\$ 25.40
Manifold	3	80133	\$ 18.40	80133	\$ 18.40	80135	\$ 19.60	80135	\$ 19.60
Orifice Nut	4	80024	\$ 2.80	80024	\$ 2.80	80024	\$ 2.80	80024	\$ 2.80
Burner Orifice, Natural Gas	5	80025	\$ 3.80	80058	\$ 3.80	80119	\$ 3.80	80169	\$ 3.80
Burner Orifice, L.P. Gas	5	80027	\$ 3.80	80060	\$ 3.80	80120	\$ 3.80	80167	\$ 3.80
Pilot Lighting Hole Cover	9	45332	\$ 1.80	45332	\$ 1.80	45332	\$ 1.80	45332	\$ 1.80
Pilot Generator	10	70098	\$ 35.90	70098	\$ 35.90	70098	\$ 35.90	70098	\$ 35.90
Pilot Tubing Assy. w/Fittings	11	70012	\$ 7.30	70012	\$ 7.30	70012	\$ 7.30	70012	\$ 7.30
Vent Safety Spill Switch/ VC	12	80102	\$ 11.80	80106	\$ 11.20	80106	\$ 11.20	80106	\$ 11.20
Vent Safety Spill Switch/ VCR	12	N/A	N/A	80105	\$ 11.20	80106	\$ 11.20	80106	\$ 11.20
Wiring Harness	13	80196	\$ 5.00	80197	\$ 5.40	80197	\$ 5.40	80198	\$ 6.30
Bulb Switch Mounting Bracket	15	45346	\$ 7.30	45346	\$ 7.30	45346	\$ 7.30	45346	\$ 7.30
Control Rod Grommet	16	80010	\$ 1.40	80010	\$ 1.40	80010	\$ 1.40	80010	\$ 1.40
Bulb Control Switch	17	70080	\$ 66.90	70080	\$ 66.90	70080	\$ 66.90	70080	\$ 66.90
Burner, Steel	18	80123	\$ 56.40	80124	\$ 59.50	80125	\$ 59.50	80126	\$ 63.60
Burner Mounting Plate Assy.	19	45817	\$ 13.90	45817	\$ 13.90	45817	\$ 13.90	45817	\$ 13.90
Casing Door	20	45125	\$ 5.20	45605	\$ 7.00	46445	\$ 8.10	46445	\$ 8.10
Casing Door Latch	21	80005	\$ 1.40	80005	\$ 1.40	80005	\$ 1.40	80005	\$ 1.40
Casing Door Knob	22	N/A	N/A	80055	\$ 1.80	80055	\$ 1.80	80055	\$ 1.80
Casing Left Side, w/Insulation	23	45102	\$ 25.70	45590	\$ 31.90	46430	\$ 34.80	47140	\$ 42.30
Casing Right Side w/Insulation	24	45112	\$ 27.00	45600	\$ 33.50	46440	\$ 36.40	47150	\$ 43.90
Casing, Back Assembly	25	45150	\$ 22.40	45612	\$ 45.10	45612	\$ 45.10	47158	\$ 49.70
Casing, Top Assy. w/Insulation	26	45052	\$ 55.40	45552	\$ 64.60	46402	\$ 69.10	47102	\$ 77.80
"VC" Casing Front with/Insulation	28	45070	\$ 59.50	45560	\$ 71.00	45560	\$ 71.00	47110	\$ 82.70
"VC" Casing Trim Top & Sides	28a	45073	\$ 21.30	45563	\$ 26.30	45563	\$ 26.30	47113	\$ 34.30
"VC" Casing Bottom Trim	28b	45074	\$ 11.00	45564	\$ 13.40	45564	\$ 13.40	47114	\$ 15.60
"VC" Casing Center Trim w/Clips	28c	45077	\$ 8.90	45567	\$ 11.00	45567	\$ 11.00	47117	\$ 13.40
"VCR" Bezel Assembly	29a	N/A	N/A	46060	\$ 71.00	46060	\$ 71.00	47610	\$ 77.00
"VCR" Upper Front Panel with/Insulation	29b	N/A	N/A	46035	\$ 31.60	46035	\$ 31.60	47585	\$ 40.50
"VCR" Lower Front Panel	29c	N/A	N/A	46040	\$ 28.30	46040	\$ 28.30	47590	\$ 32.10
"VCR" Casing Upper Trim	29d	N/A	N/A	46045	\$ 18.20	46045	\$ 18.20	47595	\$ 21.90
"VCR" Casing Lower Trim	29e	N/A	N/A	46047	\$ 16.50	46047	\$ 16.50	47596	\$ 18.60
Cozy Logo Emblem	N/A	80006	\$ 10.40	80006	\$ 10.40	80006	\$ 10.40	80006	\$ 10.40
Clips, for Cozy Emblem	N/A	80007	\$ 2.40	80007	\$ 2.40	80007	\$ 2.40	80007	\$ 2.40
Casing Base Assembly	30	45175	\$ 57.60	45640	\$ 76.60	46460	\$ 85.50	47180	\$ 93.30
Leg Levellers (4 per heater)	31	80009	\$ 1.70	80009	\$ 1.70	80009	\$ 1.70	80009	\$ 1.70
Heat Exchanger, Closed Front	32	45200	\$ 141.10	45675	\$ 187.70	46500	\$ 247.80	47200	\$ 300.70
Heat Exchanger, Radiant Front	32	N/A	N/A	46100	\$ 193.90	46825	\$ 245.40	47700	\$ 314.10
Heat Exchanger Spacer	N/A	N/A	N/A	45845	\$ 2.00	45845	\$ 2.00	45845	\$ 2.00
Rear Leg, Heat Exchanger	32A	N/A	N/A	45760	\$ 4.20	45760	\$ 4.20	45760	\$ 4.20
Draft Diverter Assembly	33	45300	\$ 40.00	45783	\$ 54.30	46558	\$ 51.70	47293	\$ 56.30
Gusset	34	*45195	\$ 3.40	*45195	\$ 3.40	*45195	\$ 3.40	*45195	\$ 3.40
Radiant Glass Panel, "VCR" Series	35	N/A	N/A	*80079	\$ 18.20	*80079	\$ 18.20	*80079	\$ 18.20
Radiant for "VCR" Series (5 per htr.)	36	N/A	N/A	80073	\$ 17.00	80073	\$ 17.00	80073	\$ 17.00
Radiant Support Rail "VCR" Series	37	N/A	N/A	*46160	\$ 5.40	*46160	\$ 5.40	*46160	\$ 5.40
Piezo Ignitor	38	80016	\$ 6.40	80016	\$ 6.40	80016	\$ 6.40	80016	\$ 6.40
Piezo Wire	39	80127	\$ 4.20	80128	\$ 4.50	80129	\$ 4.90	80129	\$ 4.90
Valve Support Bracket	41	45340	\$ 5.70	45340	\$ 5.70	45340	\$ 5.70	45340	\$ 5.70
Lighting Instructions	N/A	91267	N/C	91267	N/C	91267	N/C	91267	N/C
<b>BLOWER PARTS</b>									
				<b>CHB-3 BLOWER</b>					
Speed Control Switch w/Knob & Dec	42			70111	\$ 29.70				
Fan Switch	43			80253	\$ 8.30				
Fan Switch Bracket	44			47840	\$ 4.20				
Power Cord	45			80202	\$ 4.70				
Motor Wiring Harness	46			80256	\$ 4.20				
Blower/Motor Assembly	47			80251	\$ 62.60				
Blower Gasket - 7-1/4"	N/A			*80257	\$ 1.40				
Blower Gasket - 4-5/8"	N/A			*80258	\$ 1.40				
Junction Box Assembly	48			47850	\$ 14.10				
Junction Box Cover	49			47870	\$ 5.70				
Blower Nozzle Assembly	50			47820	\$ 14.80				
Mounting Bracket	51			47835	\$ 2.40				
Blower Platform Assy. (70 only)	N/A			47335	\$ 18.20				

**Mr. Contractor**, we only sell parts through our wholesalers, but the prices listed above are for your convenience. For prompt parts service, contact the wholesaler from which you purchased your Cozy heater. **NOTE:** Parts & schematic drawings on current models are shown at [www.cozyheaters.com](http://www.cozyheaters.com).

# IMPORTANT SAFETY BULLETIN ON YOUR GAS CONTROL AND PILOT LIGHT SYSTEM FOR HEATING EQUIPMENT

## WHAT YOU DON'T KNOW CAN HURT YOU.

Your pilot light system has been designed for safe and reliable operation. Although safety mechanisms are built-in, the potential for hazard exists. This information is intended to help you avoid these hazards.

### YOUR GAS CONTROL AND PILOT LIGHT SYSTEM

Your gas control and pilot light system has a safety device whose purpose is to shut-off the gas supply to the appliance if the pilot light goes out. If you have trouble lighting the pilot or keeping it lit, it may mean that this safety device is warning you that there is a problem with your system. Inspection and repairs or replacement must be made by a trained gas service technician.



### TAMPERING IS DANGEROUS

The pilot safety system may also not work if you do not follow the lighting instructions carefully or if you tamper with the gas control that you use to light the pilot. Tampering with the gas control, particularly with tools, can damage the safety mechanism in the control and can allow gas to leak. This can result in a fire or explosion causing property damage, personal injury or death.

### IF YOU SMELL GAS, DON'T LIGHT IT



IF YOU CAN'T LIGHT IT,  
DON'T FIGHT IT!



THIS IS NOT AN ADVERTISEMENT

### WHAT TO DO IF YOU SMELL GAS . . .

- Do not try to light any appliance.
- Do not touch any electrical switch; do not use any phone in your building.
- Immediately call your gas supplier from a neighbor's phone. Follow the gas supplier's instructions.
- If you cannot reach your gas supplier, call the fire department.

Installation and service must be performed by a qualified installer, service agency or the gas supplier.

Do not store or use gasoline or other flammable vapors and liquids in the vicinity of this or any other appliance.

### CRITICAL SAFETY POINTS TO REMEMBER ...

- Your gas has been odorized so that you can smell it. Always smell around for gas before lighting your appliance.
- Sniff for L.P.-gas at floor level. LP-gas is heavier than air and may temporarily exist at floor level.



- If you smell gas, do not attempt to light the pilot. Do not cause a spark by turning on or off electrical switches or appliances or by using the phone. Turn off the gas to the appliances and call your gas supplier from another location.
- If your gas control has gotten wet as the result of flooding or other wetting, it must be replaced immediately by a trained gas service technician. Water can lead to damage of the internal safety mechanism in the gas control and can create a hazardous condition.

# LIMITED WARRANTY

The Louisville Tin & Stove Co. warrants to the original user the accompanying product for the period specified herein, provided said product is installed, operated, maintained, serviced, and used according to the instructions and specifications accompanying the product. **AS OUTLINED IN OUR INSTRUCTIONS, ANY WARRANTY CONSIDERATIONS ARE CONTINGENT ON INSTALLATION BY A QUALIFIED INSTALLER (CONTRACTOR). SELF-INSTALLATION IS PROHIBITED AND WILL INVALIDATE YOUR WARRANTY.**

If within a period of one year from the date of installation of the product, any part supplied by the manufacturer proves to be defective due to workmanship or material, it will replace such part, provided parts have not been subjected to misuse, alteration, neglect, or accidents. The term of the warranty for the heat exchanger and burners is covered in Table A below. Any claim not made within ten (10) days after the expiration of the warranty period shall be deemed waived by the user.

The manufacturer shall have no liability or be required to perform any obligation under this warranty unless, when requested, the user returns, at the user's expense, the component or product claimed defective, to the manufacturer for inspection, to enable the manufacturer to determine if the claimed defect is covered by this warranty.

No charges for freight, labor or other expenses incurred in the repair, removal, or replacement of any product or component claimed to be defective, will be paid by the manufacturer to the user, and the manufacturer will not be liable for any expenses incurred, by the user, in remedying any defect in the product.

Service under this warranty is the responsibility of the installer. In the event service under this warranty is needed, the user of the product

shall request such service directly from the installer. If the user is unable to locate the installer, the user should write directly to the manufacturer, and the name of an alternative service source will be supplied.

The product safety registration card (packed inside the appliance) must be completed and returned to the factory.

THIS WARRANTY IS EXPRESSLY IN LIEU OF ANY OTHER WARRANTIES, EXPRESS OR IMPLIED (WHETHER WRITTEN OR ORAL). ANY IMPLIED WARRANTY OF MERCHANTABILITY OR OF FITNESS FOR A PARTICULAR PURPOSE IS EXPRESSLY LIMITED TO THE DURATION OF THE MANUFACTURER'S EXPRESS, WRITTEN WARRANTY.

UNDER NO CIRCUMSTANCES SHALL THE MANUFACTURER BE LIABLE FOR ANY SPECIAL, INDIRECT OR CONSEQUENTIAL DAMAGES OR EXPENSES ARISING DIRECTLY OR INDIRECTLY FROM ANY COMPONENT OR FROM THE USE THEREOF. THE REMEDIES SET FORTH HEREIN SHALL BE THE EXCLUSIVE REMEDIES AVAILABLE TO THE USER AND ARE IN LIEU OF ALL OTHER REMEDIES.

SOME STATES DO NOT ALLOW LIMITATIONS ON HOW LONG AN IMPLIED WARRANTY LASTS, SO THE ABOVE LIMITATIONS MAY NOT APPLY TO YOU.

SOME STATES DO NOT ALLOW THE EXCLUSION OR LIMITATION OF INCIDENTAL OR CONSEQUENTIAL DAMAGES, SO THE ABOVE LIMITATIONS OR EXCLUSIONS MAY NOT APPLY TO YOU.

THIS WARRANTY GIVES YOU SPECIFIC LEGAL RIGHTS, AND YOU MAY ALSO HAVE OTHER RIGHTS, WHICH VARY, FROM STATE TO STATE.

**TABLE A**

<u>Product</u>	<u>Warranty Period</u>	
	<u>Heat Exchanger/Tubes</u>	<u>Burners</u>
Cozy Gas Fired Floor Furnace	10 Years	10 Years
Cozy Gas Fired Wall Furnace	10 Years	10 Years
Cozy Gas Fired Vented Console Heater	10 Years	10 Years
Cozy Gas Fired Direct Vent Heater	10 Years	10 Years
Cozy Gas Fired Counterflow Furnace	10 Years	10 Years
Cozy Gas Fired Counterflow Direct Vent Furnace	10 Years	10 Years
Cozy Gas Fired Mobile Home Direct Vent Furnace	10 Years	10 Years
Cozy Gas Fired Hi-Efficient Direct Vent Wall Furnace	10 Years	10 Years
Cozy Gas Fired Direct Vent Baseboard Heater	10 Years	10 Years
Cozy Fan-Type, Direct Vent Through-The-Wall Gas Heater	10 Years	10 Years
Cozy Blue Flame Vent Free Heater	N/A	10 Years
Cozy Infra-Red Vent Free Heater	N/A	N/A

**LOUISVILLE TIN & STOVE COMPANY**

737 S. 13<sup>TH</sup> STREET - LOUISVILLE, KY. 40210