



DIRECT VENT GAS BASEBOARD HEATER



INSTALLATION AND OPERATING INSTRUCTIONS



P/N 64900 / JANUARY 2011

MODEL NUMBERS

<u>NAT. GAS</u>	<u>L.P. GAS</u>
BBT53	BBT54
BBT103	BBT104

INSTALLER: Leave this manual with the appliance.

CONSUMER: Retain this manual for future reference.

WARNING: If the information in these instructions are not followed exactly, a fire or explosion may result causing property damage, personal injury or loss of life.

- Do not store or use gasoline or other flammable vapors and liquids in the vicinity of this or any other appliance.
- **WHAT TO DO IF YOU SMELL GAS:**
 - Do not try to light any appliance.
 - Do not touch any electrical switch; do not use any phone in your building.
 - Immediately call your gas supplier from a neighbor's phone. Follow the gas supplier's instructions.
 - If you cannot reach your gas supplier, call the fire department.
- **INSTALLATION AND SERVICE MUST BE PERFORMED BY A QUALIFIED INSTALLER, SERVICE AGENCY OR THE GAS SUPPLIER.**

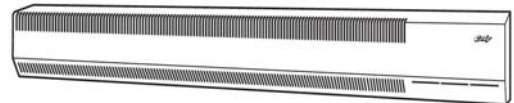
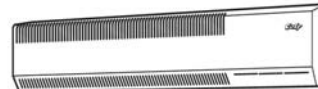

This appliance must be connected to an electrical ground.

WARNING:
CONNECT TO 115V ELECTRICAL POWER SUPPLY.
DO NOT CONNECT TO 220V POWER SUPPLY.

U.S. PATENT #
5253635

CANADIAN PATENT #
2066870



MADE IN U.S.A.

WARNING: Operation of this furnace without the properly installed, factory furnished vent system could result in Carbon Monoxide (CO) poisoning and possible death. For your safety, this furnace and the vent system should be inspected at least annually by a qualified service person.

May be installed in an aftermarket, permanently located, manufactured home (mobile home) where not prohibited by local codes. See owner's manual for details. This appliance is not convertible for use with other gases, unless a certified kit is used.

This unit is for residential use only and is not approved for installation in greenhouses, or environments involving dusty, wet, corrosive, or explosive conditions. Such conditions will invalidate the warranty and may create unsafe conditions.

NOTE: Obstruction in the vent exhaust tube or air intake tube due to insects, small animals, debris, etc. will prevent the heater from operating but DOES NOT constitute a warranty issue.

Installation, maintenance, service, trouble shooting and repair must be performed by a qualified service agency. MR./MRS. HOMEOWNER, **DO NOT** attempt any of these procedures yourself as this could expose you to property damage, personal injury, or loss of life and will invalidate your warranty.

The State of Massachusetts requires that installation and service of a gas appliance be performed by a plumber or gas fitter licensed in the Commonwealth of Massachusetts.

CONTENTS

Introduction.....	2	Wiring Diagram.....	14
Specifications and Dimensions.....	2	Removing Main Burner.....	13
Safety Rules.....	3	Proper Burner Flame.....	13
Clearances.....	4, 5	Sequence of Operation.....	15
Location.....	5	Optional Kits.....	16 - 20
Installation.....	6 - 10	Trouble Shooting.....	21 - 22
Lighting Instructions.....	11	Parts Drawing.....	23
Gas Conversion.....	12	Parts List.....	24
Burner Orifice.....	13	Warranty.....	26

INTRODUCTION

THIS IS A GAS-FIRED, DRAFT INDUCED, POWER DEPENDENT, DIRECT VENT WALL FURNACE; THAT WILL OPERATE SAFELY AND PROVIDE AN EFFICIENT SOURCE OF HEAT WHEN INSTALLED, OPERATED AND MAINTAINED AS RECOMMENDED IN THESE INSTALLATION AND OPERATING INSTRUCTIONS. READ THESE INSTRUCTIONS THOROUGHLY BEFORE INSTALLING, SERVICING, OR USING THE APPLIANCE. IF YOU DO NOT UNDERSTAND ANY PART OF THESE INSTRUCTIONS CONSULT LOCAL AUTHORITIES, OTHER QUALIFIED INSTALLERS, SERVICE TECHNICIAN, THE GAS SUPPLIER OR THE MANUFACTURER.

Mr./Mrs. Homeowner: This direct-vent, gas-fired baseboard heater has a normal operating noise level of approximately 50 db. If this unit is replacing an electric or hydronic baseboard heater you will notice a slight increase in the noise level. For comparison, the National Institute of Deafness and other Communication Disorders list the following normal sound levels: Whisper - 30 db, refrigerator humming - 40 db, a quiet office - 50 to 60 db.

SPECIFICATIONS AND DIMENSIONS

Your Direct Vent Wall Furnace is shipped complete in one carton. This carton contains the furnace, vent exhaust tube, air inlet tube, template with rough-in dimensions, installation and operating instructions, power cord (consult electrical codes), ball-valve w/flex connector, and wall thermostat.

MODEL NO.	INPUT BTU/HR.	WIDTH	DEPTH	HEIGHT	GAS CONN.	TYPE GAS	MAX. WALL Thickness	MIN. WALL Thickness
BBT53	5,000 BTU 1.45 KW	48" 122cm	5.375" 13.65cm	9.375" 23.8cm	3/8"	NAT.	16" 41cm	4" 10cm
BBT54	5,000 BTU 1.45 KW	48" 122cm	5.375" 13.65cm	9.375" 23.8cm	3/8"	L.P.	16" 41cm	4" 10cm
BBT103	9,000 BTU 2.61 KW	72" 183cm	5.375" 13.65cm	9.375" 23.8cm	3/8"	NAT.	16" 41cm	4" 10cm
BBT104	9,000 BTU 2.61 KW	72" 183cm	5.375" 13.65cm	9.375" 23.8cm	3/8"	L.P.	16" 41cm	4" 10cm

SAFETY RULES

The Direct Vent Gas Baseboard Heater and its components meet all applicable safety standards when installed as directed in this manual. For safe installation and operation of your Direct Vent Gas Baseboard Heater, read all these instructions before you begin. Failure to follow them exactly will void your warranty and may present a fire hazard.

1. Improper installation, adjustment, alteration, service, or maintenance can cause property damage, bodily injury, or death.
2. Use in other than a residential application may result in unsatisfactory performance and may void the warranty.
3. Follow all applicable codes and ordinances. If there are none, follow the latest edition of National Fuel Gas Code ANSI Z223.1 A copy may be obtained from the CSA International, or the National Fire Protection Association, Batterymarch Park, Quincy, MA. 02269. In Canada, use latest edition of CAN1-B149 installation code.
4. **DO NOT INSTALL THIS FURNACE IN A RECREATIONAL VEHICLE.**
5. Do not operate baseboard heater unless it is connected to the factory supplied vent system.
6. Check the rating label attached to the baseboard heater to be sure it is equipped for the type gas you intend to use.
7. Never use a match, candle, flame or other source of ignition to check for gas leaks. Use only soapy water or liquid detergent.
8. Have your baseboard heater and vent system inspected at least annually by a qualified service technician.
9. Before cleaning or servicing, turn off the gas and allow heater to cool.
10. Do not operate baseboard heater without all components properly installed.
11. Due to high temperatures, the baseboard heater should be located out of traffic and away from furniture and drapes.
12. Children and adults should be alerted to the hazard of high surface temperature and should be kept away to avoid burns or clothing ignition.
13. Young children should be carefully supervised when they are in the same room with the baseboard heater.
14. Do not place clothing or other flammable material on or near the heater.
15. INSTALLATION AND REPAIR SHOULD BE DONE BY A QUALIFIED SERVICE TECHNICIAN. THE BASEBOARD HEATER SHOULD BE INSPECTED BEFORE USE AND AT LEAST ANNUALLY BY A PROFESSIONAL SERVICE TECHNICIAN. More frequent cleaning may be required due to excessive lint from carpeting, bedding material, etc. It is imperative that control compartments, burner, and circulating air passageways of the heater be kept clean.
16. Do not install in a closet, alcove, or small hallway where the heater could be isolated from the space to be heated by closing a door.
17. Do not put anything around the heater or vent that will obstruct the flow of combustion and ventilation air. The flow of ventilation air through the upper and lower louvers must not be obstructed.
18. The appliance, when installed, must be electrically grounded in accordance with local codes or, in the absence of local codes, with the latest edition of National Electrical Code, ANSI/NFPA 70. In Canada, use CSA C22.1.
19. Never operate this heater without the burner sight glass in place or with the glass broken or missing.
20. If it is suspected that rising water may enter the heater, turn off the gas immediately.
21. Do not use the heater if any part has been under water. Immediately call a qualified service technician to inspect the appliance and to replace any part of the control system and any gas control which has been under water.
22. It is necessary to replace damaged gaskets or sealing material within the vent or air intake system. Failure to do so may result in property damage, personal injury, loss of life or unsatisfactory performance.
23. The cabinet cover removed for servicing must be replaced prior to operating heater.
24. This heater must not be connected to a chimney flue.

CLEARANCES

CLEARANCES TO COMBUSTIBLES	
<u>COMBUSTIBLE</u>	<u>CLEARANCE</u>
Floor.....	0 Inches (0 cm)
Right Side.....	0 Inches (0 cm)
Left Side.....	0 Inches (0 cm)
Back.....	0 Inches (0 cm)
Front.....	16 Inches (41 cm)
Ceiling.....	36 Inches (91 cm)
Draperies.....	4 Inches (10 cm)
Vent.....	2.5 Inches (6.35 cm)

If the heater is installed directly on carpeting, tile or other combustible material other than wood flooring, the heater shall be installed on a metal or wood panel extending the full width and depth of the heater.

VENT CAP CLEARANCES

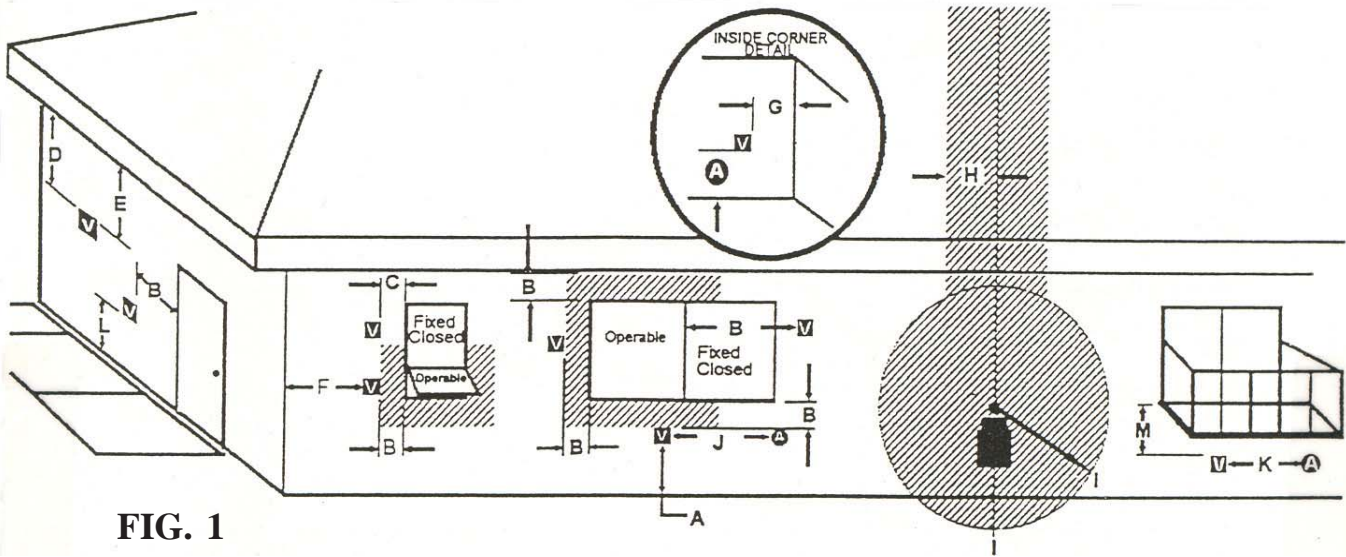

FIG. 1

OUTSIDE LOCATION FOR VENT OUTLET TERMINAL

- A = Clearance above grade, veranda, porch, deck or balcony (*12 inches [30cm] minimum)
- B = Clearance to window or door that may be opened (*6 inches [15 cm] minimum)
- C = Clearance to permanently closed window (minimum 12 inches [30 cm] recommended to prevent condensation on window)
- D = Vertical clearance to ventilated soffit located above the terminal within a horizontal distance of 2 feet [60 cm] from the center-line of the terminal (18 inches [46 cm] minimum)
- E = Clearance to unventilated soffit (12 inches [30 cm] minimum)
- F = Clearance to outside corner (12 inches [30 cm] minimum)
- G = Clearance to inside corner (24 inches [60 cm] minimum)
- H = *Not to be installed above a meter / regulator assembly within 3 feet [90 cm] horizontally from the center-line of the regulator
- I = Clearance to service regulator vent outlet (*6 feet [1.8 m] minimum)

- J = Clearance to non-mechanical air supply inlet to building or the combustion air inlet to any other appliance (*12 inches [30 cm] minimum)
- K = Clearance to a mechanical air supply inlet (*6 feet [1.8 m] minimum)
- L = † Clearance above paved side-walk or a paved driveway located on public property (*7 feet [2.1 m] minimum)
- M = Clearance under a veranda, porch, deck or balcony (*12 inches [30 cm] minimum)‡

† A vent shall not terminate directly above a sidewalk or paved driveway which is located between two single family dwellings and serves both dwellings*.

‡ Only permitted if veranda, porch, deck or balcony is fully open on a minimum of 2 sides beneath the floor.

* As specified in CGA B149 installation codes, NOTE: local codes or regulations may require different clearances.

CLEARANCES - CONT'D.

RESIDENTIAL GARAGE INSTALLATION: Gas utilization equipment in residential garages shall be installed so that all burners and burner ignition devices are located not less than 18 inches [46 cm] above the floor.

Unit should be located or protected so it is not subject to damage by a moving vehicle. Use care in selecting a good location within the garage. **DO NOT** locate the heater where heated air will be directed onto a nearby parked vehicle. Paint may discolor or rubber may harden and crack. **DO NOT** allow open or closed containers of paint, gasoline or other liquids having flammable vapors to be stored or used in the same area as the heater.

LOCATION

1. This heater must be installed on an **outside wall**.
2. For efficient performance, locate heater as centrally as possible in the area to be heated.
3. Check outside wall where vent will exit, for proper clearances (See Figure 1), compliance with local codes and clearances above grade. Also, consider exterior appearance, walkways, plantings, etc.
4. Check that a gas supply line is accessible.
5. Check that a 115 V. power supply circuit is accessible. (Do not use 220 volt current).
6. Installation must provide clearance for servicing heater.
7. If heater is installed in a basement, a 12" [30 cm] clearance must be maintained between ground level and the vent intake pipe. Do not install heater where the vent will terminate in a window well or any opening below ground level. Do not allow snow accumulation to build up within 12" [30 cm] of the vent air intake pipe.
8. Clearances must be maintained providing adequate air circulation around the heater. A minimum of 16 inches [41 cm] must be maintained from the front of the heater to furniture, doors, etc.
9. Up to three baseboard heaters may be controlled by one thermostat (provided all three heaters are in the same room with the thermostat).

THERMOSTAT LOCATION

1. Locate thermostat on an inside wall about 5 feet off the floor and 6 feet from the baseboard heater, accessible to wiring, service and adjustment, in a frequently used room such as a living room, rec room, etc.
2. Do not locate thermostat in unusual heating conditions such as in sunlight, close to lamps, TV sets, radiators, registers, or other heat producing appliances.
3. Do not locate thermostat in unusual cooling conditions such as on an outside wall, or one separating an unheated room, or in drafts from stairwells, doors, windows, etc.
4. Do not locate thermostat where air circulation is poor such as in a corner, alcove, over furniture or the wall behind an open door.

OPTIONAL KITS

For special installation applications and modifications, the following kits are available from your local dealer. To ensure safe, efficient operation of your Direct Vent Gas Baseboard be sure to use only authorized kits.

Table 1: Special adaptation and modification kits available for use with the Direct Vent Baseboard Heaters.

MODEL #	DESCRIPTION	CONTENTS
VWSK5/10	Vent Weather Seal Kit	2" diameter PVC pipe, external wall seal, O-ring, 2 PVC straps, PVC glue, instructions.
VRK5/10	Vent Riser Kit	Wall mount plate, 21-1/2" stainless steel vent riser, instructions
SVCK5/10	Side Valve Concealer Kit	4" cabinet extension, wall plate, screws, instructions
BVCK5/10	Bottom Valve Concealer Kit	4" cover, wall plate, screws, instructions

ATTENTION ALL CANADIAN CONTRACTORS/INSTALLERS: Before installing this heater into a multi-family hi-rise exceeding four stories, contact the local building code inspector to verify the building construction complies with the **Progressive Collapse** requirements as listed in the National Building Code of Canada 2005.

INSTALLATION

WARNING: Failure to follow these instructions carefully could result in poor performance, property damage, personal injury, or loss of life.

STEP 1. LOCATE VENT OPENING (Requires a 2-1/2" hole when not using vent weather seal kit).

- a) Select area on wall where heater will be installed.
- b) Check outside vent termination for proper clearances. See Figure 1.
- c) Locate studs behind heater location.
- d) Using template supplied, mark location for 2-1/2" hole between studs. See Figure 2.
- e) Cut vent openings through both the inside and outside walls, being sure to maintain level across both openings.

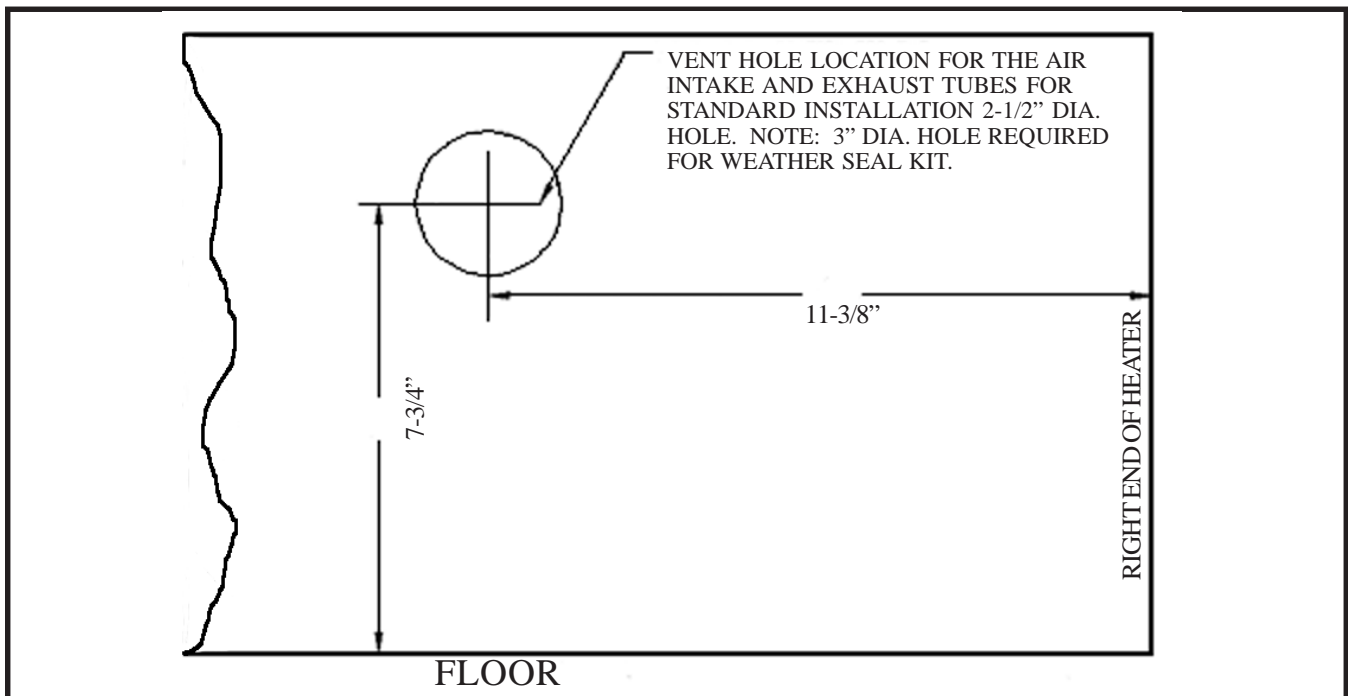

INSTALLATION - Cont'd.

STEP 2. ROUGHING GAS SUPPLY – (See Figure 3)

- a) Select the bottom, rear or right side to bring the factory supplied flexible gas line assembly out of the heater.
- b) The valve must be connected only by means of a pipe union of the ground joint type. Mr. Installer, hold gas valve when connecting gas supply line.
- c) Install at least a 3/8" gas line. Contact local gas supplier if any questions.
- d) Install a drip leg in gas supply line immediately upstream from the gas connection to heater, (see local codes), and provide a 1/8" N.P.T. plugged tapping, accessible for test gauge connection and an individual manual shut off valve accessible within room where heater is installed. The heater and its individual shut off valve must be disconnected from the gas supply piping system during any pressure testing of that system at test pressures in excess of 1/2 psig (3.5Pa). The heater must be isolated from the gas supply piping system by closing its individual manual shut off valve during any pressure testing of the gas supply piping system at test pressures equal to or less than 1/2 psig (3.5Pa).
- e) Test all connections for leaks using a soapy solution. NEVER USE AN OPEN FLAME TO TEST FOR LEAKS.
- f) The maximum inlet gas supply pressure for natural and L.P./Propane gas is 1/2 p.s.i. or 14" w.c. The minimum inlet as supply pressure for the purpose of adjustment is 4.5" w.c. for natural gas and 11.0" w.c. for L.P./Propane gas.

YOU SHOULD HAVE:

- 1 – Baseboard Heater
- 1 – Exhaust Tube
- 1 – Air Intake Tube
- 1 – 4" [10 cm] Stainless steel flexible connector with a manual shut-off valve
- 1 – Template to locate venting and mounting positions (in package with manual)
- 1 – Vent Sealing Gasket
- 1 – Manual
- 1 – Weather Seal
- 1 - Wall thermostat w/wire & staples

STEP 3. PREPARING TO INSTALL THE BASEBOARD HEATER

- a) Open the carton and carefully remove the Direct Vent Baseboard Heater.
- b) Remove the cover of the baseboard heater's cabinet by removing the screws at the bottom front of the cover. (See Figure 4.)
- c) Make sure that all of the components illustrated have been included.

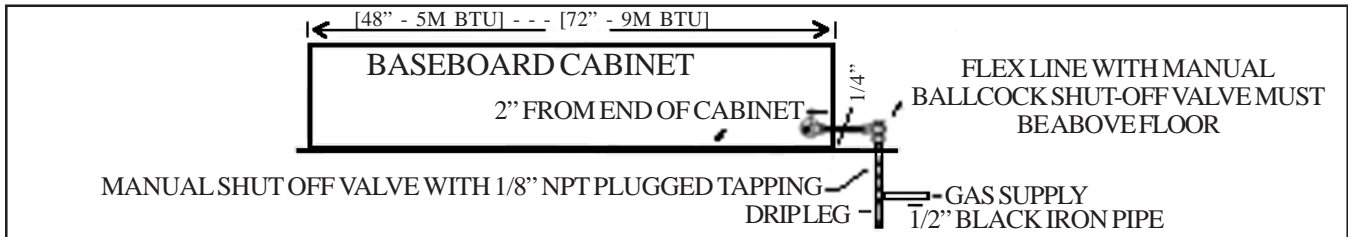

FIGURE 3

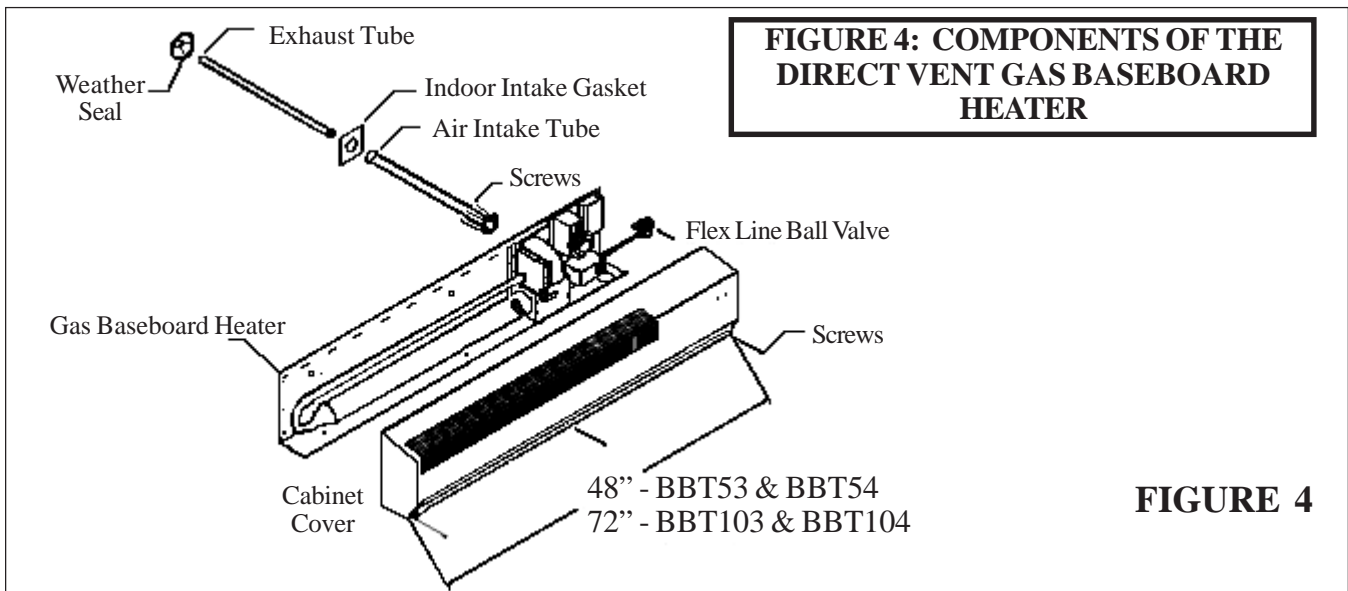

FIGURE 4

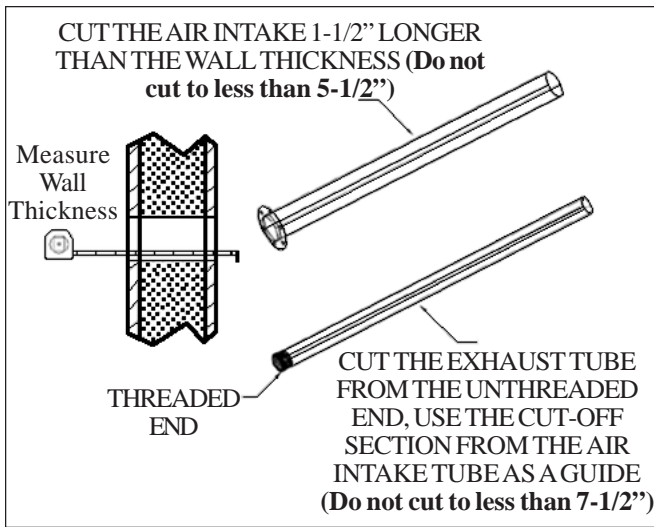

FIGURE 5

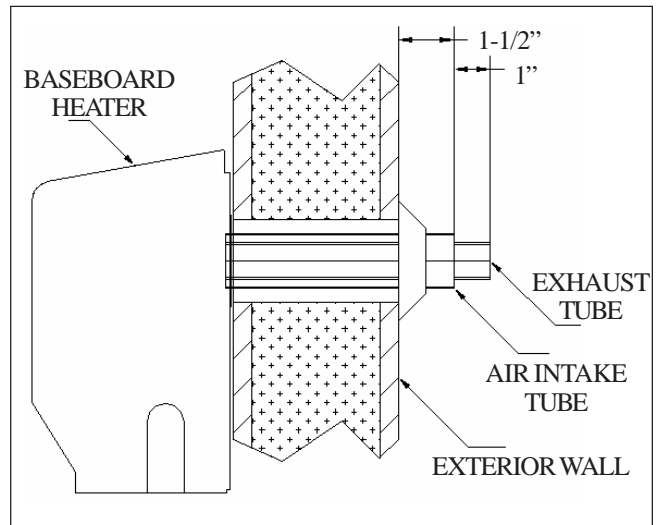

FIGURE 6

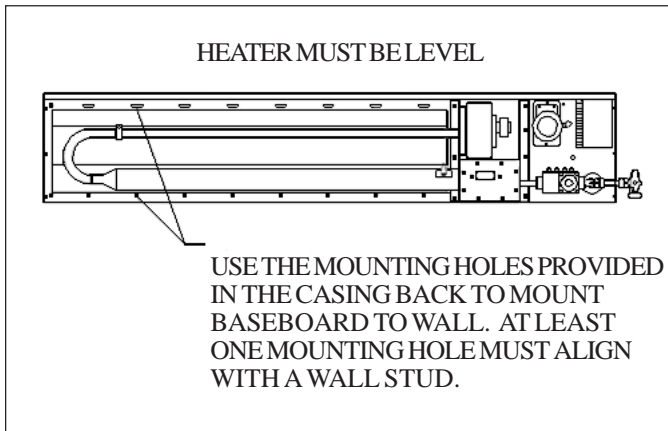

FIGURE 7

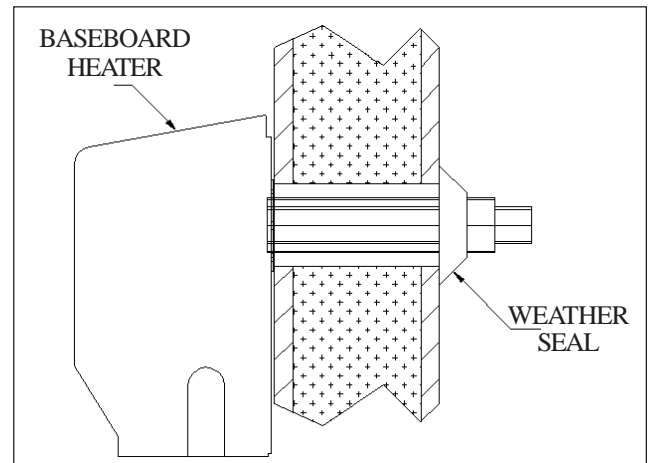

FIGURE 8

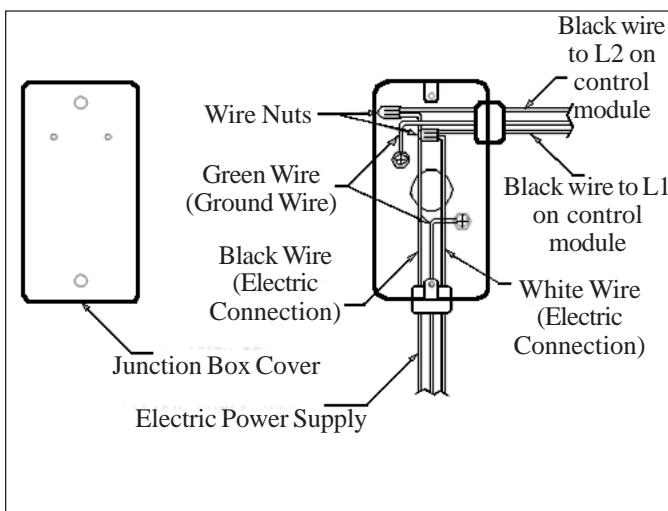

FIGURE 9

INSTALLATION - Cont'd.

STEP 4. INSTALLING THE BASEBOARD HEATER

- a) Use only factory supplied parts. Do not modify in any way.
- b) Using a measuring tape, measure the thickness of the wall. See Figure 5.
- c) Using a tube cutter, cut the air intake pipe 1.5" [3.8 cm] longer than the wall thickness (no less than 5-1/2"). Measuring from the threaded end, cut the vent exhaust pipe 3.0" [7.62 cm] longer than the wall thickness (no less than 7.5" {19.05 cm}). After cutting, check the inside of both pipes for burrs. Both pipes must be smooth and clean without any reduction to the inside diameter. NOTE: Correct pipe length is critical to proper operation.
- d) Hand tighten the vent exhaust tube into the draft inducer outlet. Then apply a pipe wrench to snug. **DO NOT** use excessive torque as this could force the inducer into a bind resulting in excessive noise and/or inducer failure. Do not use pipe thread sealant.
- e) Attach air intake pipe to back of heater using six #8 screws provided. See Figure 6.
- f) Slide the indoor intake gasket over the air intake pipe and against the back of the heater.
- g) Place the vent tubes into center of the hole cut through wall and slide the entire heater towards the wall, feeding the 115 V. line and thermostat wires through the appropriate holes in the rear, bottom, or right side of the heater.
- h) Level and secure heater to wall with screws (not provided) through mounting holes in back of heater. Anchors (not provided) may be required. See Figure 7.
NOTE: Mounting the heater on a wall that is not plumb or over tightening mounting screws may cause undue stress which may result in excessive noise during warm-up and cool-down.
- i) From outside the house, slide weather seal over air intake pipe and against outside wall. See Figure 8.

STEP 5. ELECTRICAL CONNECTIONS

If this heater is replacing a 220 volt electric baseboard heater, the circuit must be converted to 115 volt by a licensed electrician. This appliance must only be connected to a properly grounded 115 V. electrical circuit. **DO NOT CONNECT TO 220 VOLT SUPPLY CIRCUIT.**

USING FACTORY INSTALLED POWER CORD

- a) Unwrap power cord and plug directly into nearest 115 volt electrical outlet. Do not use extension cord.

HARD WIRING HEATER

- a) Remove junction box cover. See Figure 9.
- b) Disconnect factory wired power cord, remove power cord from junction box and discard.
- c) Install electrical wiring into junction box through appropriate knockout. Secure with strain relief fitting supplied.
- d) Connect wires to factory installed wires in junction box. Secure with wire nuts provided.
- e) Secure ground wire under screw holding junction box to heater back. See Figure 9.
- f) Replace and secure junction box cover.

CAUTION: Label all wires prior to disconnection when servicing controls. Wiring errors could cause improper or dangerous operation. Verify proper operation after servicing.

STEP 6. THERMOSTAT CONNECTION

- a) This heater is designed to operate on a 24 V. thermostat (supplied). Do not connect to existing line voltage thermostat. **NOTE: Should the homeowner desire a programmable thermostat, only use models that are wireless. Never use a programmable thermostat that requires a direct wire connection from the thermostat to the heater.**
- b) Connect thermostat wire to purple and white wire in control compartment (labeled thermostat wire). Secure connection with wire nuts.

CONTROLLING MORE THAN ONE HEATER WITH A SINGLE THERMOSTAT

- c) Up to a maximum of three baseboard heaters may be controlled by a single thermostat, provided all heaters are in the same room with the wall thermostat.
- d) If more than one baseboard heater is being controlled from a single thermostat, the 115 V. supply must be supplied from the same circuit. When wiring more than one baseboard heater to a single 24 V. thermostat, the baseboard heaters must be hard wired in parallel. Do not use individual cord sets. See Figure 10.

INSTALLATION - Cont'd.

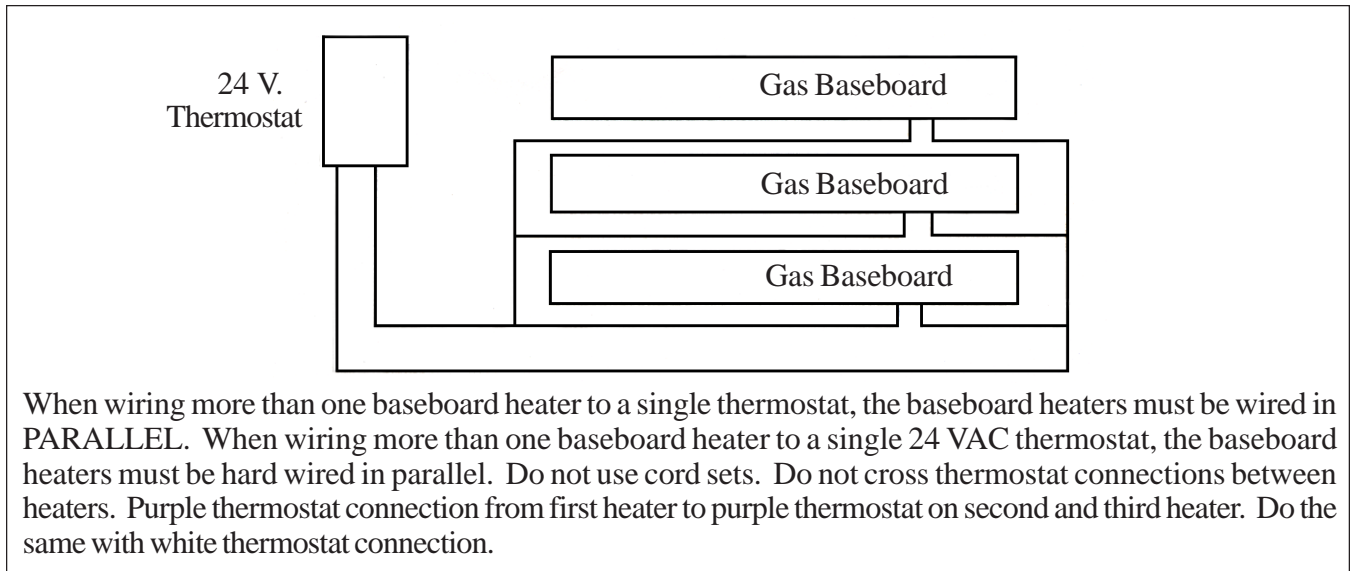

FIGURE 10

- e) The anticipator setting on the thermostat should be equivalent to the current draw of the total number of valves being controlled.

NUMBER OF BASEBOARD HEATERS	ANTICIPATOR SETTING
1	.1 AMP
2	.2 AMP
3	.3 AMP

STEP 7. COMPLETING INSTALLATION

- Connect gas supply line to flex gas line/shut-off valve from heater.
- Turn gas supply on. Check connections with soapy solution.
- Plug power cord into grounded 115 V. outlet or turn power on if hard wired.
- Replace cabinet cover and secure with three screws at bottom.

Heater is now installed, follow lighting instructions to put heater in operation.



During initial warm-up the heater may smoke slightly. Provide adequate ventilation should this occur.

FOR YOUR SAFETY READ BEFORE OPERATING

WARNING: If you do not follow these instructions exactly, a fire or explosion may result causing property damage, personal injury or loss of life.

- A. This appliance does not have a pilot. It is equipped with an ignition device which automatically lights the burner. Do not try to light the burner by hand.
- B. BEFORE OPERATING smell all around the appliance area for gas. Be sure to smell next to the floor because some gas is heavier than air and will settle on the floor.
- WHAT TO DO IF YOU SMELL GAS:
- Do not try to light any appliance.
 - Do not touch any electric switch; do not use any phone in your building.
 - Immediately call your gas supplier from a neighbor's phone. Follow the gas supplier's instructions.
- C. Use only your hand to push in or turn the gas control knob. Never use tools. If the knob will not push in or turn by hand, don't try to repair it, call a qualified service technician. Force or attempted repair may result in a fire or explosion.
- D. Do not use this appliance if any part has been under water. Immediately call a qualified service technician to inspect the appliance and to replace any part of the control system and any gas control which has been under water.
- If you cannot reach your gas supplier, call the fire department.

OPERATING INSTRUCTIONS

1. STOP! Read safety information on this label.
2. Set the thermostat to the lowest setting.
3. Turn off all electric power to the appliance.
4. This appliance is equipped with an ignition device which automatically lights the burner. Do not try to light the burner by hand.
5. Turn gas control knob clockwise  to "OFF". Do not force.
6. Wait five (5) minutes to clear out any gas. If you smell gas, STOP! Follow "B" in safety information on this label. If you don't smell gas, go to next step.
7. Turn gas control knob counterclockwise  to "ON".
8. Turn on all electric power to the appliance.
9. Set thermostat to desired setting.
10. If the appliance does not operate, follow instructions "To Turn Off Gas To Appliance" and call your service technician or gas supplier.

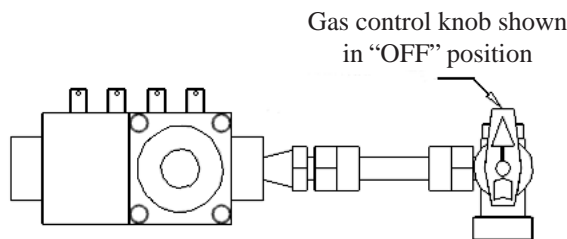

TO TURN OFF GAS TO APPLIANCE

1. Set the thermostat to lowest setting.
2. Turn off all electric power to the appliance if service is to be performed.
3. Turn gas control knob clockwise  to "OFF". Do not force.

P/N91428 03/04

GAS CONVERSION

The gas control valve supplied on this heater is field convertible.

CAUTION: A qualified installer or service technician must perform any conversion of this gas control valve.

CONVERSION INSTRUCTIONS

1. Remove the converting seal cap. See Figure A. **WARNING:** Do not remove or tamper with any other valve components.
2. Remove the black rubber gasket from the down side of the converting seal cap and reinstall gasket on opposite side of converting seal cap. Gasket must be on down (valve) side of converting seal cap. See Figure A.
3. Invert the converting seal cap and reinstall.
4. Insure that the desired gas (LP for liquefied petroleum or NAT for natural gas) symbol is visible after reassembly of cap. See Figure A.
5. Remove the burner orifice and replace with burner orifice of correct size for your type of gas and elevation. See orifice chart in these instructions.
6. Check for gas leaks.
7. Using a manometer, check for correct manifold pressure. 3.5" w.c. for natural gas and 10.0" w.c. for L.P.

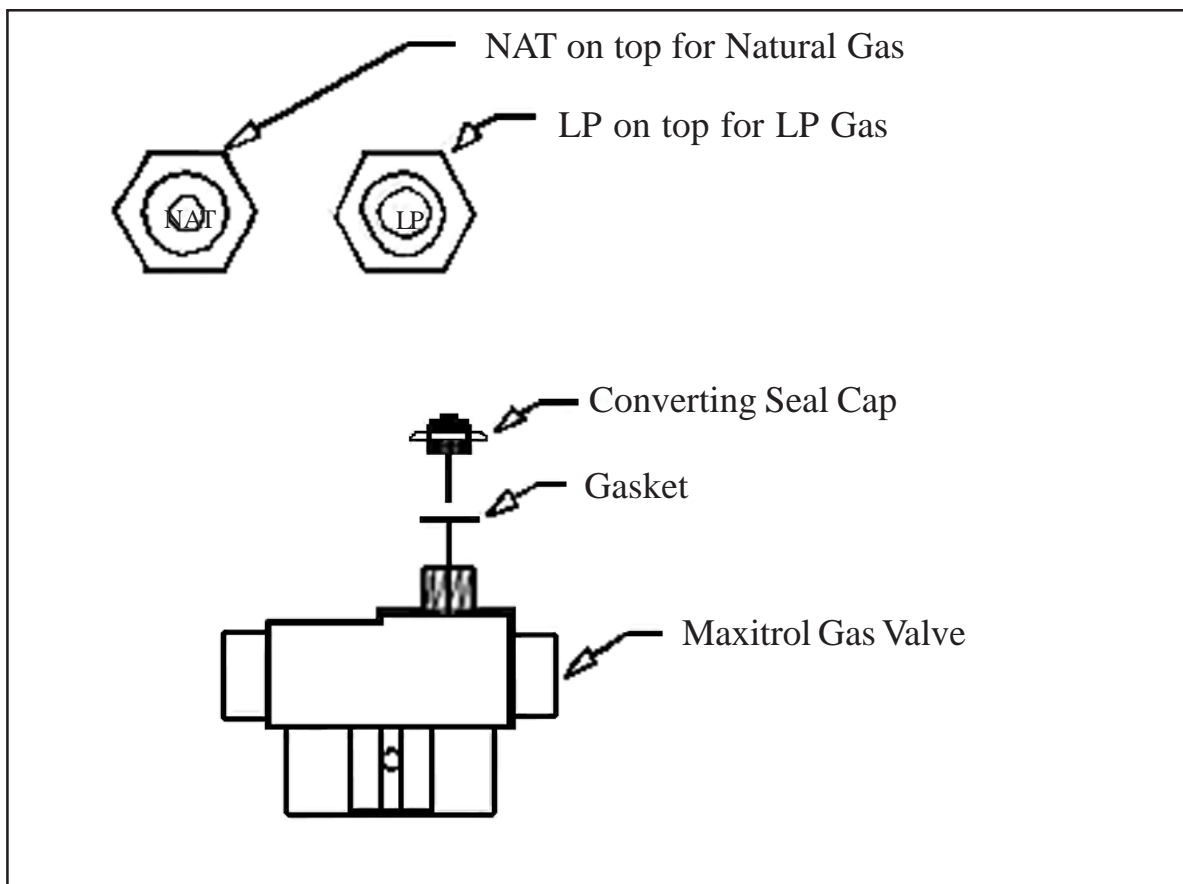

FIGURE A

PROPER BURNER FLAME

The burner flame may be observed through the sight glass located in the burner box cover. See Figure 11. A proper flame will have a dark blue inner mantle, with a lighter blue outer mantle that extends from the burner into the heat exchanger tube, (see Figure 12). There is no primary air adjustment on the burner, and proper flame is assured since the correct manifold pressure and orificing has been done at the factory for elevations up to 2,000 feet.

TO REMOVE MAIN BURNER FOR INSPECTION AND CLEANING

- a. Turn off all electrical supply to heater.
- b. Turn off gas supply.
- c. Remove cabinet cover.
- d. Remove burner box cover. See Figure 13.
- e. Remove two (2) screws holding burner to burner bracket. See Figure 13.
- f. Burner can now be slid forward off orifice, lift up, slide back and out of burner box.
- g. Clean or replace as needed.
- h. Reinstall by reversing Steps "f" through "a".

BURNER ORIFICE

This heater is orificed at the factory for elevations up to 2,000 ft. If installed above 2,000 ft., the BTU input must be reduced 4% per 1,000 ft. See the following orifice chart for the proper orifice for a specific elevation. Orifice change must be completed by a qualified installer or service technician.

SPECIFIC ELEVATIONS

MODEL NO.	0 to 2,000'	2,000' 4,000'	4,000' 6,000'	6,000' 8,000'	8,000' - 10,000'
<u>NATURAL GAS</u>					
BBT53	56	57	57	59	60
BBT103	1.45mm	54	54	55	55
<u>L.P. GAS</u>					
BBT54	70	71	71	72	73
BBT104	64	65	65	66	68

ORDER KIT #49800 44-1 HIGH ALTITUDE KIT FOR NAT. OR L.P. GAS.

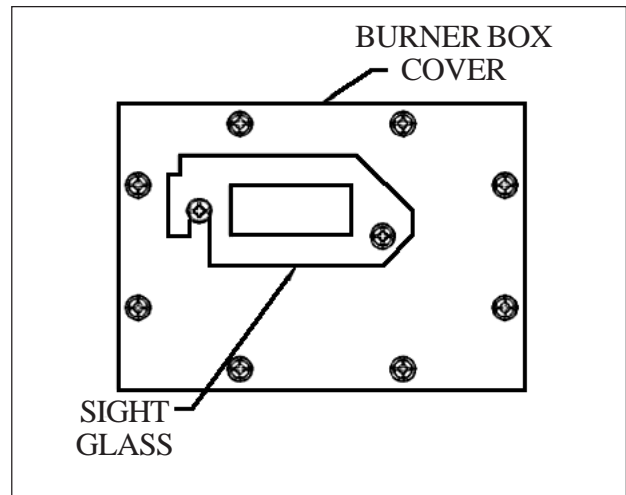

FIGURE 11

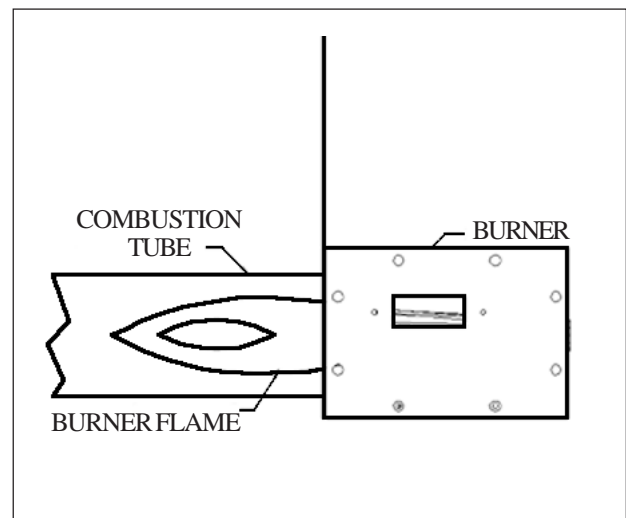

FIGURE 12

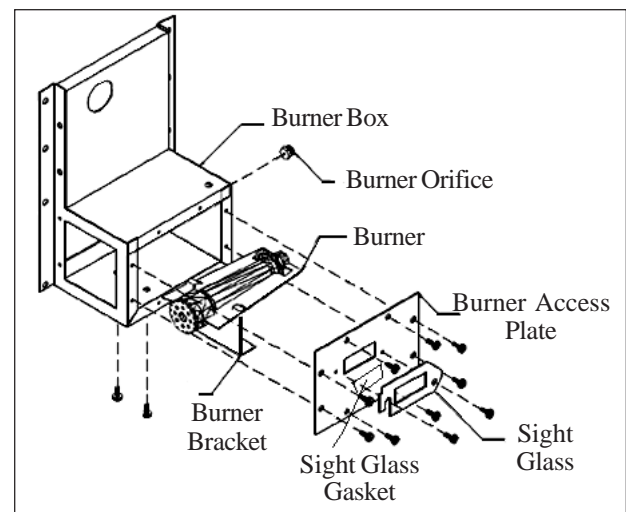

FIGURE 13

WIRING

If any of the original wire supplied with heater has to be replaced, it must be replaced with type 105 Degree C wire or its equivalent.

CAUTION: Label all wires prior to disconnection when servicing controls. Wiring errors can cause improper and dangerous operation.

Verify proper operation after servicing.

WIRING DIAGRAM - BBT53 & BBT54

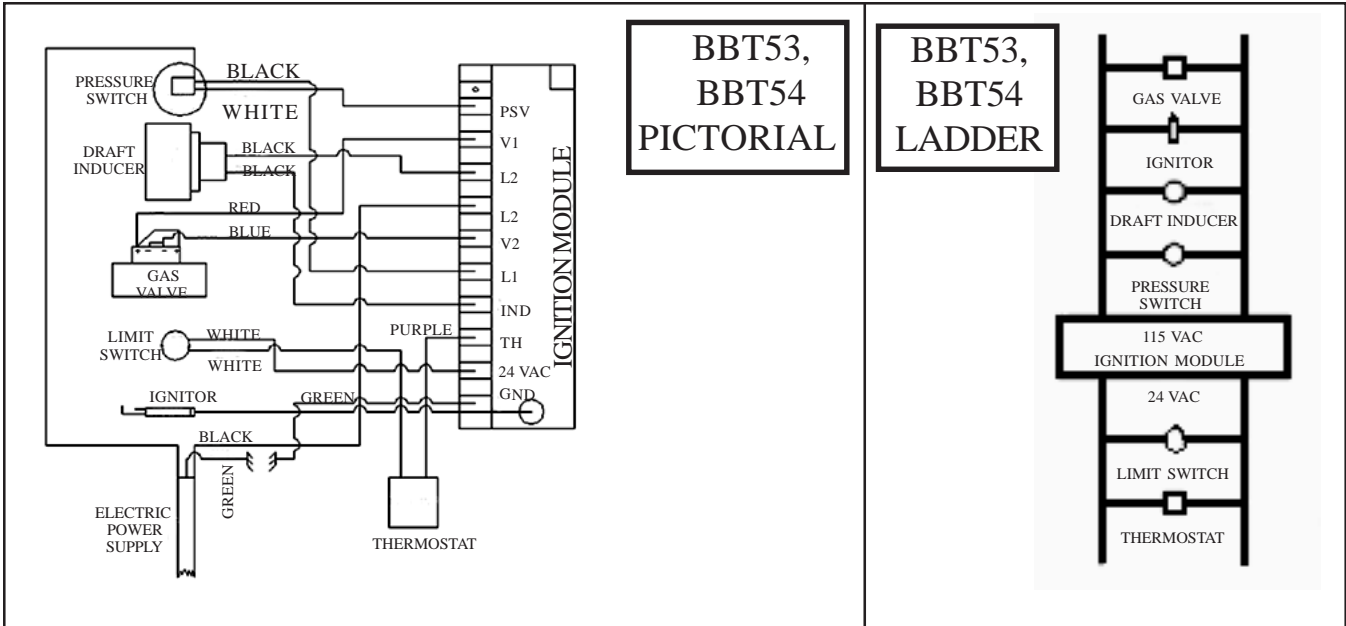

WIRING DIAGRAM - BBT103 & BBT104

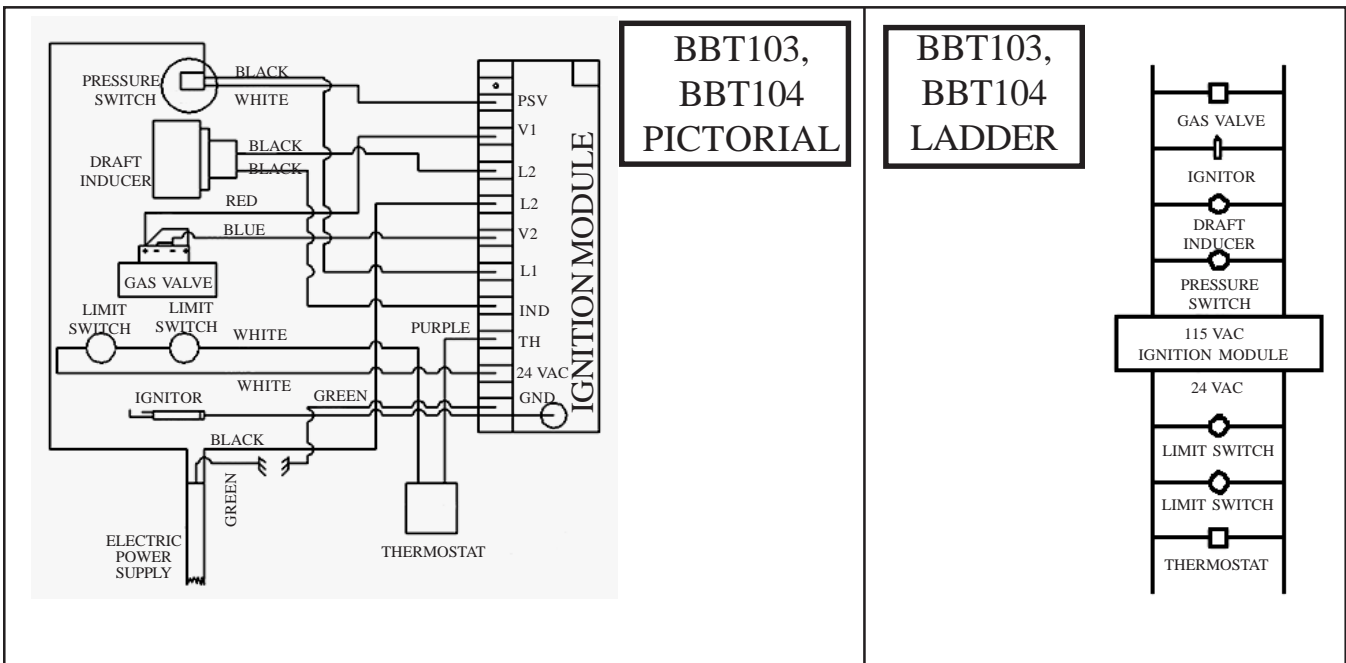

SEQUENCE OF OPERATION

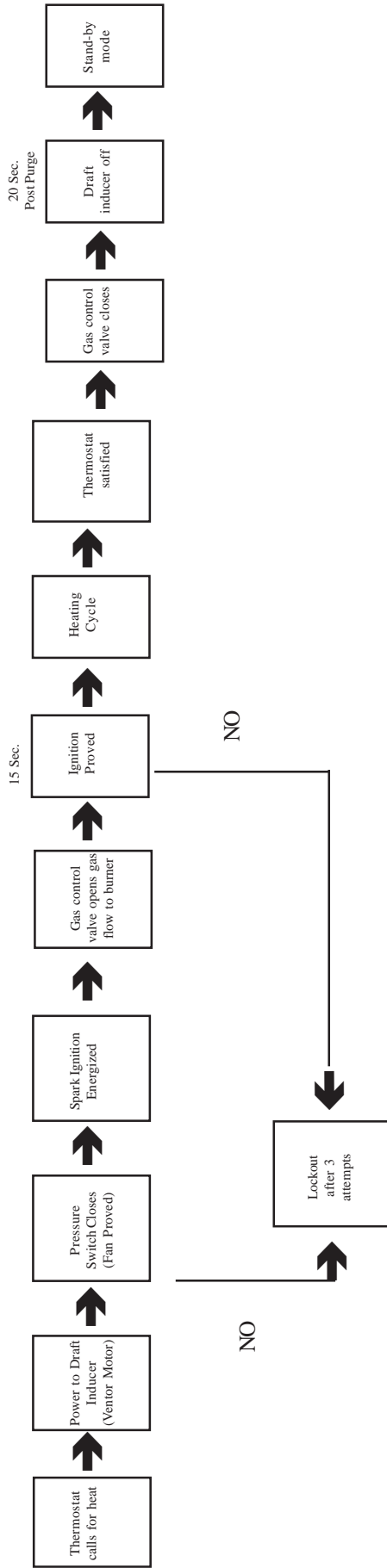

STEP

- 1) Thermostat calls for heat.
- 2) Inducer turns on.
- 3) Pressure switch closes.
- 4) Power to ignitor.
- 5) Gas flow to burner.
- 6) Burner ignition proven.

NOTE: If there is a malfunction in any of the above steps, the sequence will stop at that point and return to Step 2. If after 3 attempts malfunction still occurs, control will go into lockout mode for one hour. This one hour lockout can be bypassed by resetting the thermostat, or interrupting power.

- 7) Thermostat satisfied.
- 8) Gas valve closes.
- 9) Inducer turns off.

HEATER IS NOW IN STANDBY MODE.

VRK5/10 VENT RISER KIT

INSTALLATION INSTRUCTIONS

WARNING: If the information in these instructions are not followed exactly, poor performance, fire or explosion may result causing property damage, personal injury or loss of life.

This kit was designed and certified for use with a Cozy Gas Baseboard Heater only. Use only factory supplied parts. Do not alter kit. This kit must be installed by a qualified installer or service technician.

WARNING: DO NOT INSTALL IN WINDOW WELL OR BELOW GRADE WHERE WATER MAY ACCUMULATE. BOTTOM OF VENT RISER KIT MUST NOT TOUCH THE GROUND. SPECIAL PRECAUTIONS MUST BE TAKEN TO PREVENT SNOW BUILD-UP OVER KIT.

STEP 1. Install Cozy gas baseboard heater per installation instructions.

STEP 2. Verify air intake tube extends 1-1/2" past surface of outside wall and the vent exhaust tube extends 2-1/2" past surface of outside wall. See Figure 1.

STEP 3. Slide the Vent Riser Kit over the intake and exhaust tubes and back flush against wall. NOTE: Louvered section of kit must be up. See Figure 2.

STEP 4. Mark and drill six (6) mounting holes in wall matching six (6) holes in flange on the Vent Riser Kit. Depending on wall material, anchors (not provided) may be required. See Figure 2.

STEP 5. Secure Vent Riser Kit to wall. See Figure 2.

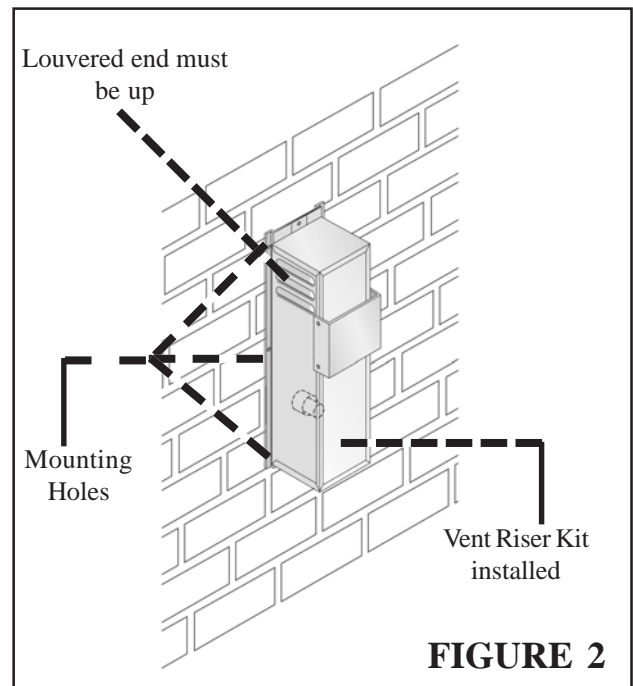
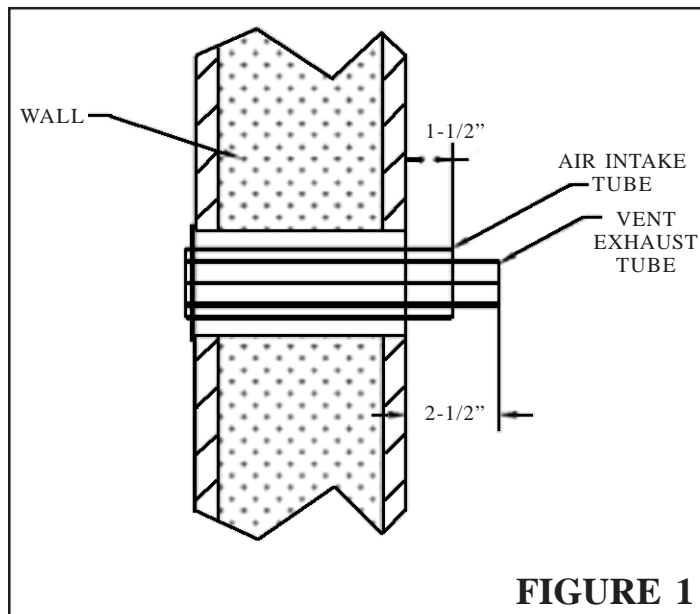

SIDE VALVE CONCEALER KIT - SVCK5/10

NOTE: This kit has been designed and certified for use with a Cozy gas baseboard heater only. Use only factory supplied kit and components. This kit must be installed by a qualified installer or service technician.

- STEP 1.** With the offset up and out from the wall, place the mounting bracket flush to the right side of the heater cabinet. Align the top of the mounting plate with the top of heater cabinet. Mark the location of the mounting holes. See Figure 1.
- STEP 2.** Drill holes where marked. Depending on wall material, install wall anchors (not provided) if needed.
- STEP 3.** Secure mounting plate to wall with screws (not provided).
- STEP 4.** Attach the cover to the mounting plate by placing the cover top edge over the offset on the mounting plate. Push the cover in toward wall until catch snaps into place. See Figure 2.
- STEP 5.** For access to the manual gas shut off valve, locate finger handle at the bottom of the cover. Pull out until snap catch releases then lift cover up to remove from mounting plate. See Figure 2.

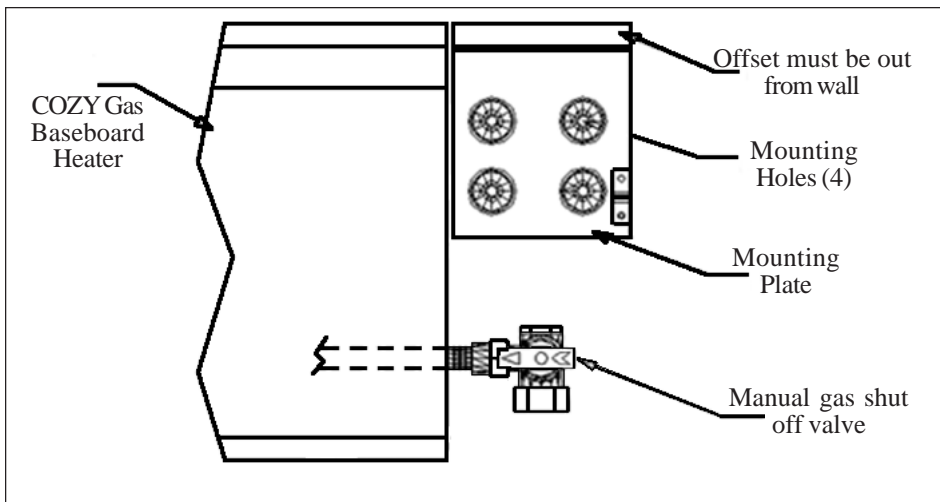

FIGURE 1

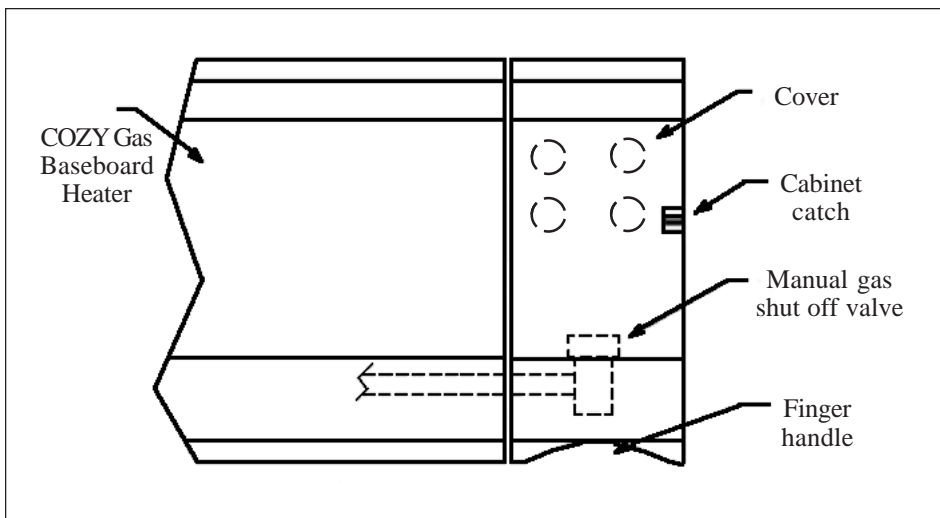
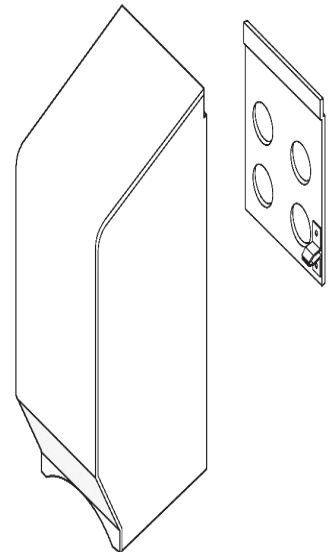

FIGURE 2



BOTTOM VALVE CONCEALER KIT - BVCK5/10

NOTE: This kit has been designed and certified for use with a Cozy gas baseboard heater only. Use only factory supplied kit and components. This kit must be installed by a qualified installer or service technician.

- STEP 1.** Place the mounting plate against the wall and flush with the bottom of the gas baseboard heater. The mounting plate must cover the manual gas shut off valve. See Figure 1. Mark the location of the mounting holes.
- STEP 2.** Drill holes where marked. Depending on wall material, install anchors (not provided) if needed.
- STEP 3.** Secure mounting plate to wall with screws (not provided).
- STEP 4.** Attach the cover to the mounting plate by lining up the two catches inside the cover with catches on mounting plate. Push cover toward wall until catches snap into place. See Figure 2.
- STEP 5.** For access to the manual gas shut-off valve, grasp the cover on both sides and pull out until the snap catches release.

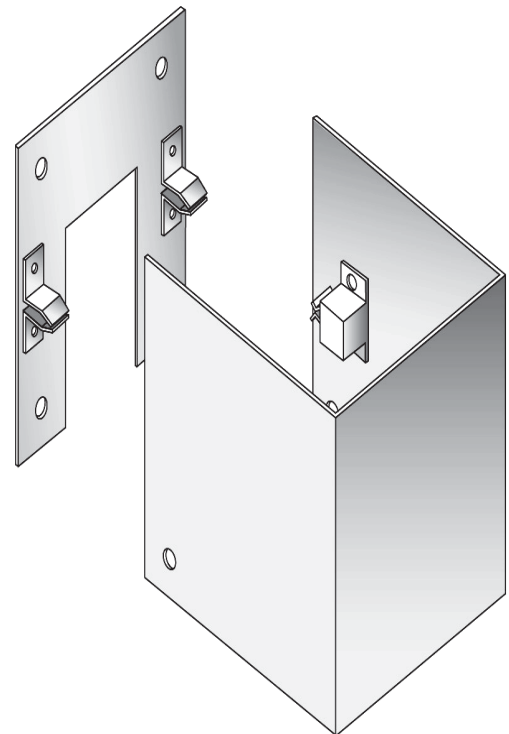
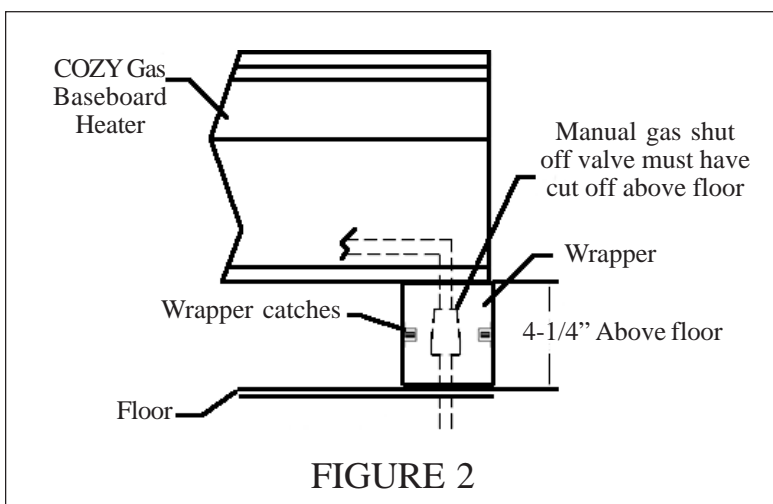
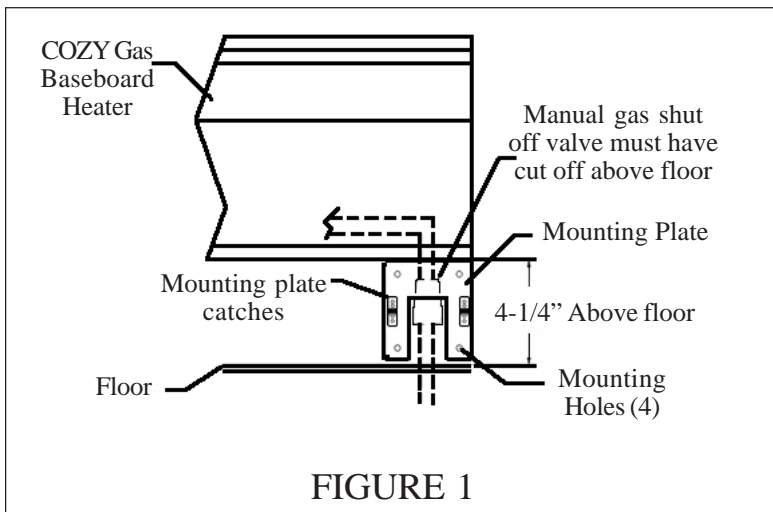

VENT WEATHER SEAL KIT - VWSK5/10

NOTE: This kit has been designed and certified for use with a Cozy gas baseboard heater only. Use only factory supplied kit and components. See Figure 1 for parts list of Vent Weather Seal Kit. This kit must be installed by a qualified installer or service technician.

- STEP 1.** Change the location for the vent by following Figure 1 in the installation and operating instructions provided with the Cozy gas baseboard heater.
- STEP 2.** Drill a three (3) inch diameter hole through the wall of the chosen location.
- STEP 3.** Measure the wall thickness.
- STEP 4.** Using a two (2) inch tube cutter, cut the PVC wall sleeve seven-eighths (7/8") inch **longer** than the measured wall thickness. See Figure 2.
- STEP 5.** Clean the PVC sleeve and apply PVC cement (provided) on opposite sides of sleeve. Place straps on cement leaving eight (8) inches past sleeve end. Wait ten (10) minutes for cement to dry before proceeding to Step 6. See Figure 2.
- STEP 6.** Apply petroleum jelly or an equivalent lubricant to the outside of the weather seal. The lubricant will make it easier to push the weather seal through the wall. See Figure 2.
- STEP 7.** From inside, hold the wall sleeve with the PVC straps lined up horizontally. Push the PVC pipe and weather seal slowly through the wall until the weather seal is completely outside the wall. See Figure 3.
- STEP 8.** Pull the PVC straps toward you to pull the weather seal firmly against the outside wall. See Figure 3.
- STEP 9.** Being careful to keep the PVC straps lined up horizontally and pulled tight to maintain the outside seal, bend the straps away from sleeve and secure to wall. Depending on type of wall, anchors (not provided) may be required. See Figure 4.
- STEP 10.** First, put blue pipe plug in PVC pipe to prevent insulation from getting inside! Insert nozzle from a tube of foam insulation between the wall and the wall sleeve. Starting at the weather seal, slowly inject the foam, working towards the inside wall. **CAUTION:** Read the manufacturers instructions on the can of foam for special instructions and warnings.
- STEP 11.** Wait fifteen (15) minutes for foam to dry, cut away any excess from around sleeve on inside wall. If Cozy gas baseboard heater will be installed at a later date, leave the pipe plug in the wall sleeve to seal the vent hole.
- STEP 12.** Install the Cozy gas baseboard heater per the installation instructions provided with heater.
- STEP 13.** Slide the O-ring over the air intake tube to a position approximately two (2") inches from the end of the tube. See Figure 5.
- STEP 14.** Remove pipe plug from wall sleeve.
- STEP 15.** Apply petroleum jelly or equivalent lubricant around the outside of the O-ring. Insert the air intake tube through the PVC wall sleeve until back of heater is against the wall. Secure heater to wall.

CONT'D. --- ILLUSTRATIONS - NEXT PAGE

VENT WEATHER SEAL KIT - Cont'd.

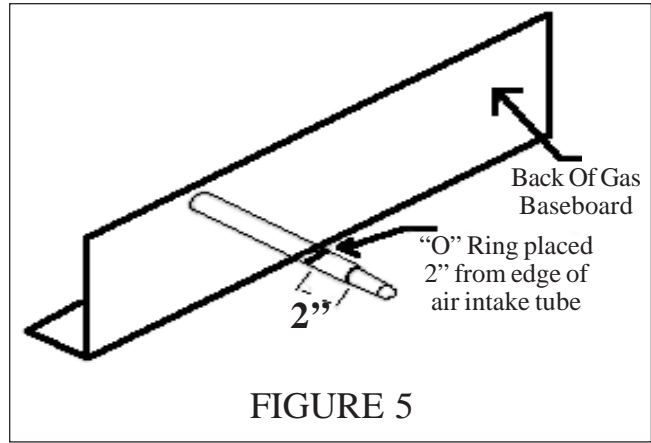
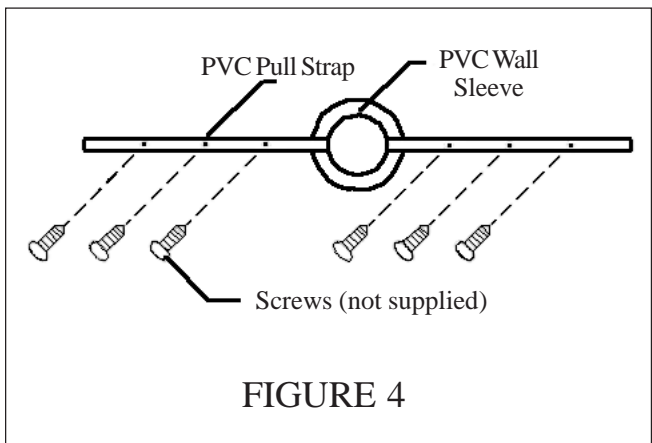
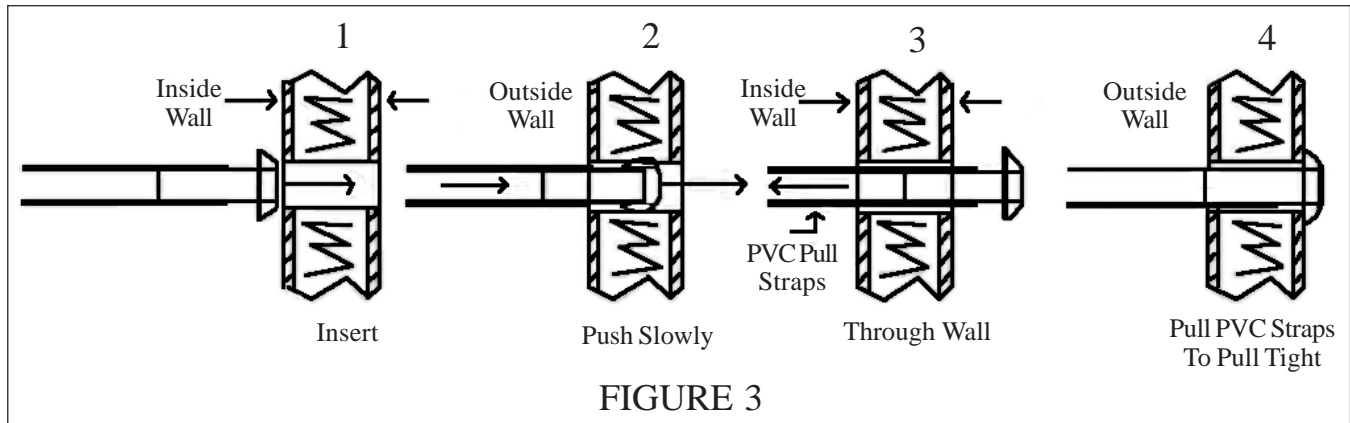
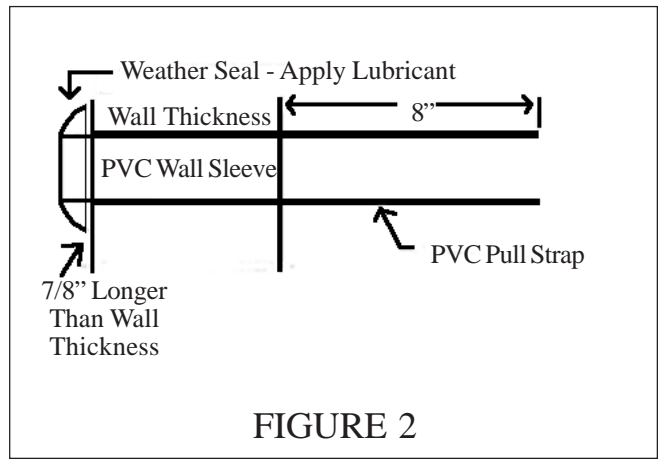
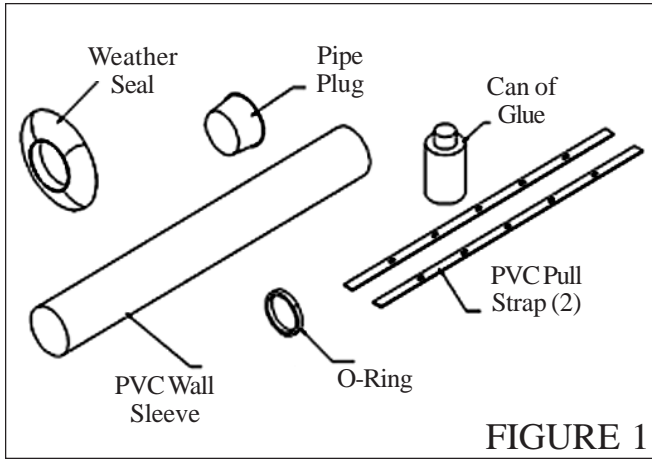

TROUBLE SHOOTING CHART

For use by a qualified installer or service technician.

SYMPTOM	POSSIBLE CAUSES	CORRECTIVE ACTION
Flame too large	<ol style="list-style-type: none"> 1. Defective operator section of valve. 2. Burner orifice too large. 3. If installed above 2,000 ft. 	<ol style="list-style-type: none"> 1. Replace valve. 2. Check with local gas company for proper orifice size and replace. 3. See burner orifice section, Page 12.
Yellow burner flame	<ol style="list-style-type: none"> 1. Clogged burner ports. 2. Obstruction around vent cap. 	<ol style="list-style-type: none"> 1. Remove burners and check for obstructions in throats, ports, and orifices. Clean - but do not enlarge ports or orifices. 2. Make sure area around vent cap is clear, be sure vent system is sealed.
Gas odor	<ol style="list-style-type: none"> 1. Gas leak. 	<ol style="list-style-type: none"> 1. See Page 1.
Delayed Ignition	<ol style="list-style-type: none"> 1. Low gas pressure. 2. Igniter not properly located. 	<ol style="list-style-type: none"> 1. Check gas supply pressure. 2. Check ignitor location and correct if necessary.
Failure to ignite	<ol style="list-style-type: none"> 1. Main gas off. 2. Thermostat not set high enough to call for heat. 3. Clogged burner orifice. 4. Incorrect wiring. 5. Defective valve. 6. No power to unit. 7. Defective pressure switch. 8. Orifice undersized. 	<ol style="list-style-type: none"> 1. Open all manual gas valves. 2. Set thermostat to higher temperature. 3. Clean burner orifice (do not enlarge). 4. Check wiring diagram. 5. Replace valve. 6. Check power supply. 7. Replace pressure switch. 8. Check orifice size. See burner orifice chart, Page 13.
Burner won't turn off	<ol style="list-style-type: none"> 1. Defective or damaged thermostat wire, or thermostat. 2. Thermostat location. 3. Defective or sticking valve. 4. Excessive gas pressure. 5. Defective or damaged thermostat. 	<ol style="list-style-type: none"> 1. Can be checked by removing wire from control board terminal. If burner goes off, replace thermostat. 2. Re-locate thermostat out of drafts, hot, or cold spots. 3. Replace valve. 4. Contact utility supplying gas. 5. Replace thermostat.
Incorrect gas input	<ol style="list-style-type: none"> 1. Gas input not checked. 2. Clogged orifice. 	<ol style="list-style-type: none"> 1. Re-check gas input. 2. Clean orifices with a smooth wood toothpick, do not enlarge.
Not enough heat	<ol style="list-style-type: none"> 1. Furnace undersized. 2. Temperature dial set too low. 3. Incorrect supply pressure. 	<ol style="list-style-type: none"> 1. This is especially true when a dwelling or room is enlarged. Have the heat loss calculated and compare to furnace output. Your gas company can supply you with this information. If furnace is undersized, replace with correct size unit, or add up to two more heaters. 2. Raise temperature setting. 3. Check supply pressure.
Too much heat	<ol style="list-style-type: none"> 1. Temperature dial set too high. 2. Combination control valve stuck open. 	<ol style="list-style-type: none"> 1. Lower temperature setting. 2. Replace combination control valve.
Main burner goes out during normal operation	<ol style="list-style-type: none"> 1. Defective flame sensor. 2. Input too high. 3. Cover around pilot lighter hole not air tight. 4. Vent tubes not properly installed or sealed. 5. Limit switch opens. 6. Exhaust or air intake tubes blocked. 	<ol style="list-style-type: none"> 1. Check voltage and replace if low. 2. Check input rate. 3. Tighten screws securing sight glass. Check and replace gasket if needed. 4. Follow instructions. Check both exhaust and air intake tubes, and vent cap. Be sure all gaskets are in place and properly sealed. Use only tubes and vent cap supplied. Do not alter vent tubes or cap. Check wall thickness and tube lengths. 5. Check rate - remove any obstructions to circulating air. 6. Remove obstruction. Check for snow.
Excessive noise	<ol style="list-style-type: none"> 1. Heater not installed plumb. 2. Vent tube over-tightened in draft inducer. 3. Defective draft inducer. 	<ol style="list-style-type: none"> 1. Check wall and floor making sure both are square. Square heater as required. 2. Loosen vent tube slightly. Make sure draft inducer returns to square. 3. Replace draft inducer.

TROUBLE SHOOTING CONTROL BOARD
For use by a qualified installer or service technician.

TO IMPROVE DIAGNOSING AND SERVICING, THIS CONTROL MODULE IS EQUIPPED WITH A SELF-DIAGNOSING RED INDICATOR LIGHT. TO INDICATE STAND-BY MODE AND PROPER OPERATION, THIS LIGHT WILL REMAIN OFF. IF THERE SHOULD BE A MALFUNCTION, THE LIGHT WILL FLASH A VARYING NUMBER OF TRIES WITH A PAUSE BETWEEN EACH SERIES OF FLASHES. THE NUMBER OF FLASHES WILL INDICATE WHICH CIRCUIT TO CHECK.

# OF FLASHES	REASON FOR INDICATION	POSSIBLE CAUSES	CORRECTIVE ACTION
1	Air flow fault	a.) Pressure switch tubing disconnected or damaged. b.) Pressure switch tubing to wrong connections. c.) Wire disconnected or damaged. d.) Obstruction in vent pipe. e.) Defective draft inducer.	a.) Connect or replace tubing. b.) Correct tubing connection. c.) Replace or connect wire. d.) Remove obstructions. e.) Replace draft inducer.
2	Flame - no call for heat	a.) Defective gas valve. b.) Defective control module. c.) Defective thermostat wire.	a.) Replace gas valve. b.) Replace control module. c.) Check and replace thermostat wire.
3	Ignition Lock Out (3 Attempts) Heater is in one hour lockout mode. This one hour lockout can be bypassed by resetting the thermostat	a.) Defective ignitor. b.) Ignitor cable disconnected - <u>no gas to burner</u> . c.) Manual gas control in OFF position. d.) Loose or damaged wire to gas valve. e.) Orifice undersized.	a.) Replace ignitor. b.) Connect ignition cable. c.) Turn manual gas control to ON position. d.) Connect or replace wire to gas valve. e.) Check orifice size. See Orifice Chart, Page 13.

MAINTENANCE INSTRUCTIONS

For correct and safe operation, keep heater and heater area clean. At regular intervals, turn control valve to OFF, let heater cool and clean inside control and heat exchanger compartments.

To clean outside cover, use a damp cloth, do not use any kind of solvent or cleaning fluid as they may leave a residue that could burn or give off odors when heater is turned on.

Have heater, including vent system, checked, cleaned and/or repaired by a qualified service technician prior to use each year.

Follow a regular service and maintenance schedule for safe and efficient operation.

Do not obstruct combustion, ventilation or circulating air.

If any components are removed, make sure all gaskets are reinstalled and are in good condition. If any sign of damage, replace gasket as this is a sealed system and must be air-tight for proper operation. DO NOT operate heater with any gasket missing or damaged. Failure to replace a missing or damaged gasket may result in property damage, personal injury or loss of life.

SERVICE RECORD

DATE	DATE	DATE

DIRECT VENT GAS BASEBOARD HEATER

MODEL NUMBERS

BBT53 / BBT103 - NAT. GAS

BBT54 / BBT104 - L.P. GAS

Prices and specifications subject
to change without notice.

All prices are F.O.B. factory.

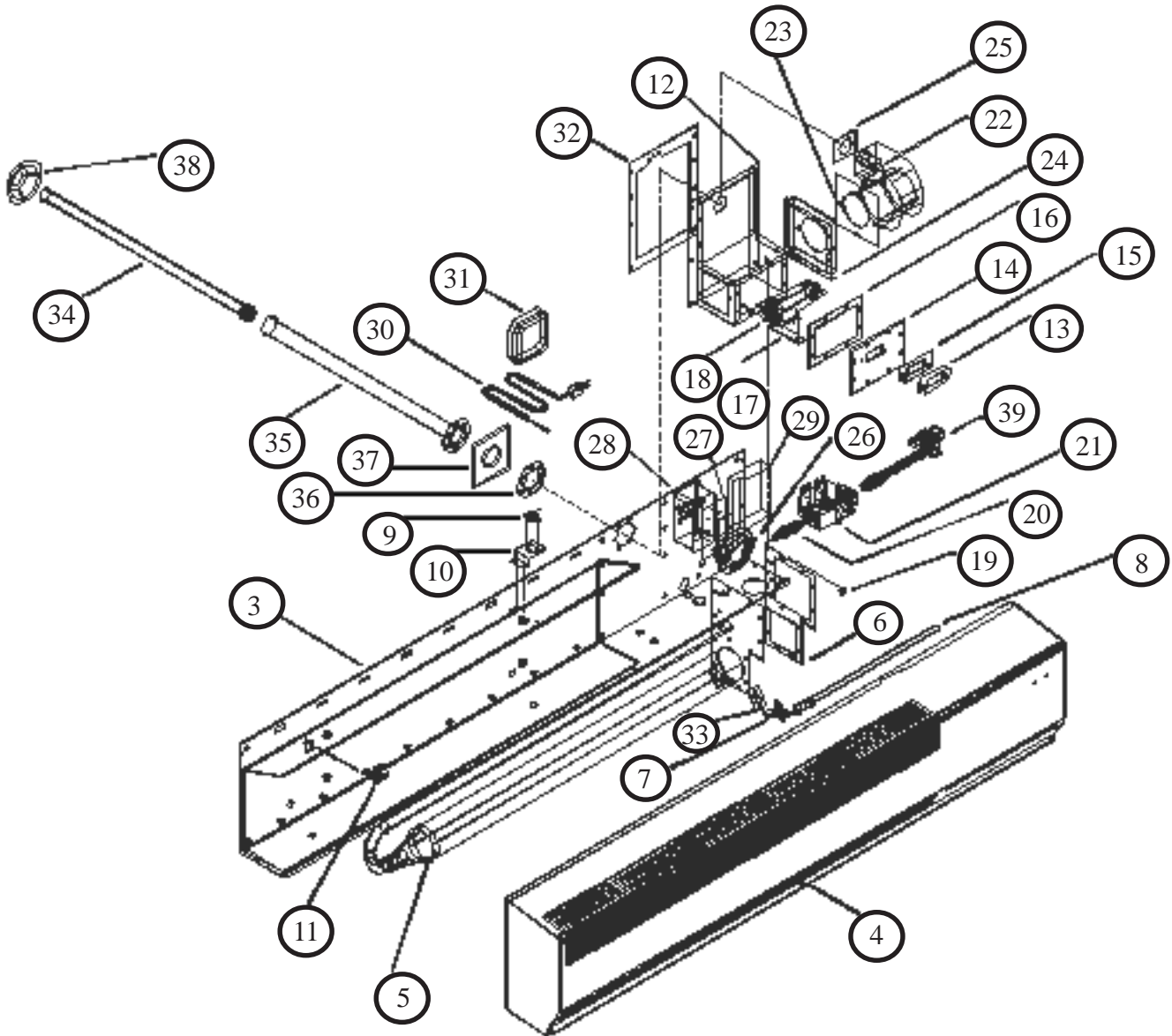

ATTN: CONTRACTOR and SERVICE TECHNICIANS, we only sell parts through our wholesalers, but the prices listed are for your convenience. For prompt parts service, contact the wholesaler from which you purchased your Cozy heater. **NOTE:** Parts prices & schematic drawings on current models are shown at www.cozyheaters.com.

HOW TO PROPERLY ORDER PARTS: In addition to part description and part number, please give model number, serial number, and type of gas used. This information can be found on the rating plate located inside the cabinet cover.

	NAT.	BBT53		BBT103	
MODEL NUMBER	L.P.	BBT54		BBT104	
	REF.	PART	LIST	PART	LIST
PART DESCRIPTION	NO.	NO.	PRICE	NO.	PRICE
Cabinet Base	3	21055	\$ 83.30	21555	\$ 113.00
Cabinet Cover Assembly w/End Caps	4	21025	\$ 167.00	21525	\$ 213.00
Heat Exchanger	5	21175	\$ 218.60	21675	\$ 229.00
Heat Exchanger Gasket - 7-7/8x4-25/32"	6	64151	\$ 7.40	64151	\$ 7.40
Igniter	7	64009	\$ 26.10	64009	\$ 26.10
Igniter Cable	8	64210	\$ 19.50	64210	\$ 19.50
Limit Switch	9	64086	\$ 6.20	*64085	\$ 6.20
Limit Switch Bracket	10	21125	\$ 2.60	*21125	\$ 2.60
Limit Switch Wire 27" White	N/A	64200	\$ 1.60	64200	\$ 1.60
Limit Switch Wire 26" White	N/A	64202	\$ 1.40	N/A	N/A
Limit Switch Wire 46" White	N/A	N/A	N/A	64198	\$ 2.10
Limit Switch Wire 17" White	N/A	N/A	N/A	64199	\$ 1.40
Heat Exchanger Clamp	11	64011	\$ 1.40	64011	\$ 1.40
Burner Box/ Air Drop Assembly	12	21067	\$ 39.70	21067	\$ 39.70
Sight Glass Assembly	13	43252	\$ 7.60	43252	\$ 7.60
Burner Access Plate	14	21115	\$ 5.00	21115	\$ 5.00
Sight Glass Gasket - 1-3/8x3"	15	72067	\$ 1.80	72067	\$ 1.80
Burner Access Plate Gasket - 3-1/2x5"	16	64150	\$ 3.60	64150	\$ 3.60
Burner Support Bracket	17	21130	\$ 5.00	21130	\$ 5.00
Burner	18	64005	\$ 15.50	64004	\$ 12.20
Burner Orifice, Natural Gas	19	95315	\$ 4.00	64252	\$ 4.00
Burner Orifice, L.P. Gas	19	64251	\$ 4.00	64253	\$ 4.00
Manifold	20	64008	\$ 20.90	64008	\$ 20.90
Gas Valve, Natural Gas, CV200 - 110 Volt	21	64105	\$ 99.00	64105	\$ 99.00
Gas Valve, L.P. Gas, CV200 - 110 Volt	21	64106	\$ 99.00	64106	\$ 99.00
Draft Inducer	22	±64081	\$ 191.00	±64081	\$ 191.00
Draft Inducer Gasket - 4-1/16x3-29/32"	23	64152	\$ 3.40	64152	\$ 3.40
Draft Inducer Mounting Plate	24	21140	\$ 24.90	21140	\$ 24.90
Draft Inducer Outlet Gasket - 2-1/8x1-3/4"	25	64154	\$ 1.90	64154	\$ 1.90
Oil for Draft Inducer	N/A	64083	\$ 5.70	64083	\$ 5.70
Pressure Switch	26	±64066	\$ 23.70	±64067	\$ 23.70
Junction Box Cover	27	64053	\$ 2.30	64053	\$ 2.30
Junction Box	28	78059	\$ 4.90	78059	\$ 4.90
Control Module	29	64007	\$ 203.70	64007	\$ 203.70
Thermostat Wire Lead 6" Purple	N/A	64215	\$ 1.40	64215	\$ 1.40
(Pos. +) Gas Valve 8" Red	N/A	64216	\$ 1.90	64216	\$ 1.90
(Neg. -) Gas Valve 7" Dark Blue	N/A	64217	\$ 1.70	64217	\$ 1.70
Pressure Switch 8-1/2" White	N/A	64218	\$ 1.40	64218	\$ 1.40
Pressure Switch 11" Black	N/A	64219	\$ 1.60	64219	\$ 1.60
Power Cord Connector 5-1/2" Black	N/A	64220	\$ 1.40	64220	\$ 1.40
Ground 9" Green	N/A	64221	\$ 1.40	64221	\$ 1.40
Power Cord	30	80202	\$ 4.90	64205	\$ 6.60
Thermostat Wire	N/A	74518	\$ 1.60	74518	\$ 1.60
Thermostat	31	78355	\$ 23.40	78355	\$ 23.40
Vacuum Tube 24" 1/4X3/8" Silicone Tubing	N/A	72544	\$ 2.10	72544	\$ 2.10
Air Box Gasket - 8-3/4x6-1/2"	32	64153	\$ 11.20	64153	\$ 11.20
Vent Exhaust Tube	34	64015	\$ 79.50	64015	\$ 79.50
Air Intake Tube Assembly	35	21150	\$ 49.70	21150	\$ 49.70
Air Intake Tube Gasket - 2-1/2" Circle	36	64020	\$ 1.50	64020	\$ 1.50
Indoor Intake Gasket - 3-3/4x3-3/4"	37	64155	\$ 2.00	64155	\$ 2.00
Weather Seal	38	64405	\$ 12.50	64405	\$ 12.50
Flex Gas Line/Shut-off Valve Assembly	39	64072	\$ 28.70	64072	\$ 28.70

±Units with "11" lead Serial Numbers.

Units with "10" lead Serial Numbers or Older (see below):

64075 Inducer - "07" and older - Order 21775 "BBIK" and new pressure switch (#64066 on BBT53/4) OR (64067 on BBT103/4)

64076 Inducer - "08" - "10" Serial Numbers - Order 21775 "BBIK" Kit.

ATTN: CONTRACTOR and SERVICE TECHNICIANS, we only sell parts through our wholesalers, but the prices listed above are for your convenience. For prompt parts service, contact the wholesaler from which you purchased your Cozy heater. NOTE: Parts & schematic drawings on current models are shown at www.cozyheaters.com

IMPORTANT SAFETY BULLETIN ON YOUR GAS CONTROL AND PILOT LIGHT SYSTEM FOR HEATING EQUIPMENT

WHAT YOU DON'T KNOW CAN HURT YOU.

Your pilot light system has been designed for safe and reliable operation. Although safety mechanisms are built-in, the potential for hazard exists. This information is intended to help you avoid these hazards.

YOUR GAS CONTROL AND PILOT LIGHT SYSTEM

Your gas control and pilot light system has a safety device whose purpose is to shut-off the gas supply to the appliance if the pilot light goes out. If you have trouble lighting the pilot or keeping it lit, it may mean that this safety device is warning you that there is a problem with your system. Inspection and repairs or replacement must be made by a trained gas service technician.



TAMPERING IS DANGEROUS

The pilot safety system may also not work if you do not follow the lighting instructions carefully or if you tamper with the gas control that you use to light the pilot. Tampering with the gas control, particularly with tools, can damage the safety mechanism in the control and can allow gas to leak. This can result in a fire or explosion causing property damage, personal injury or death.

IF YOU SMELL GAS, DON'T LIGHT IT



**IF YOU CAN'T LIGHT IT,
DON'T FIGHT IT!**



THIS IS NOT AN ADVERTISEMENT

WHAT TO DO IF YOU SMELL GAS . . .

- Do not try to light any appliance.
- Do not touch any electrical switch; do not use any phone in your building.
- Immediately call your gas supplier from a neighbor's phone. Follow the gas supplier's instructions.
- If you cannot reach your gas supplier, call the fire department.

Installation and service must be performed by a qualified installer, service agency or the gas supplier.

Do not store or use gasoline or other flammable vapors and liquids in the vicinity of this or any other appliance.

CRITICAL SAFETY POINTS TO REMEMBER . . .

- Your gas has been odorized so that you can smell it. Always smell around for gas before lighting your appliance.
- Sniff for L.P.-gas at floor level. LP-gas is heavier than air and may temporarily exist at floor level.



- If you smell gas, do not attempt to light the pilot. Do not cause a spark by turning on or off electrical switches or appliances or by using the phone. Turn off the gas to the appliances and call your gas supplier from another location.
- If your gas control has gotten wet as the result of flooding or other wetting, it must be replaced immediately by a trained gas service technician. Water can lead to damage of the internal safety mechanism in the gas control and can create a hazardous condition.

LIMITED WARRANTY

The Louisville Tin & Stove Co. warrants to the original user the accompanying product for the period specified herein, provided said product is installed, operated, maintained, serviced, and used according to the instructions and specifications accompanying the product. **AS OUTLINED IN OUR INSTRUCTIONS, ANY WARRANTY CONSIDERATIONS ARE CONTINGENT ON INSTALLATION BY A QUALIFIED INSTALLER (CONTRACTOR). SELF-INSTALLATION IS PROHIBITED AND WILL INVALIDATE YOUR WARRANTY.**

If within a period of one year from the date of installation of the product, any part supplied by the manufacturer proves to be defective due to workmanship or material, it will replace such part, provided parts have not been subjected to misuse, alteration, neglect, or accidents. The term of the warranty for the heat exchanger and burners is covered in Table A below. Any claim not made within ten (10) days after the expiration of the warranty period shall be deemed waived by the user.

The manufacturer shall have no liability or be required to perform any obligation under this warranty unless, when requested, the user returns, at the user's expense, the component or product claimed defective, to the manufacturer for inspection, to enable the manufacturer to determine if the claimed defect is covered by this warranty.

No charges for freight, labor or other expenses incurred in the repair, removal, or replacement of any product or component claimed to be defective, will be paid by the manufacturer to the user, and the manufacturer will not be liable for any expenses incurred, by the user, in remedying any defect in the product.

Service under this warranty is the responsibility of the installer. In the event service under this warranty is needed, the user of the product

shall request such service directly from the installer. If the user is unable to locate the installer, the user should write directly to the manufacturer, and the name of an alternative service source will be supplied.

The product safety registration card (packed inside the appliance) must be completed and returned to the factory.

THIS WARRANTY IS EXPRESSLY IN LIEU OF ANY OTHER WARRANTIES, EXPRESS OR IMPLIED (WHETHER WRITTEN OR ORAL). ANY IMPLIED WARRANTY OF MERCHANTABILITY OR OF FITNESS FOR A PARTICULAR PURPOSE IS EXPRESSLY LIMITED TO THE DURATION OF THE MANUFACTURER'S EXPRESS, WRITTEN WARRANTY.

UNDER NO CIRCUMSTANCES SHALL THE MANUFACTURER BE LIABLE FOR ANY SPECIAL, INDIRECT OR CONSEQUENTIAL DAMAGES OR EXPENSES ARISING DIRECTLY OR INDIRECTLY FROM ANY COMPONENT OR FROM THE USE THEREOF. THE REMEDIES SET FORTH HEREIN SHALL BE THE EXCLUSIVE REMEDIES AVAILABLE TO THE USER AND ARE IN LIEU OF ALL OTHER REMEDIES.

SOME STATES DO NOT ALLOW LIMITATIONS ON HOW LONG AN IMPLIED WARRANTY LASTS, SO THE ABOVE LIMITATIONS MAY NOT APPLY TO YOU.

SOME STATES DO NOT ALLOW THE EXCLUSION OR LIMITATION OF INCIDENTAL OR CONSEQUENTIAL DAMAGES, SO THE ABOVE LIMITATIONS OR EXCLUSIONS MAY NOT APPLY TO YOU.

THIS WARRANTY GIVES YOU SPECIFIC LEGAL RIGHTS, AND YOU MAY ALSO HAVE OTHER RIGHTS, WHICH VARY, FROM STATE TO STATE.

TABLE A

<u>Product</u>	<u>Warranty Period</u>	
	<u>Heat Exchanger/Tubes</u>	<u>Burners</u>
Cozy Gas Fired Floor Furnace	10 Years	10 Years
Cozy Gas Fired Wall Furnace	10 Years	10 Years
Cozy Gas Fired Vented Console Heater	10 Years	10 Years
Cozy Gas Fired Direct Vent Heater	10 Years	10 Years
Cozy Gas Fired Counterflow Furnace	10 Years	10 Years
Cozy Gas Fired Counterflow Direct Vent Furnace	10 Years	10 Years
Cozy Gas Fired Mobile Home Direct Vent Furnace	10 Years	10 Years
Cozy Gas Fired Hi-Efficient Direct Vent Wall Furnace	10 Years	10 Years
Cozy Gas Fired Direct Vent Baseboard Heater	10 Years	10 Years
Cozy Fan-Type, Direct Vent Through-The-Wall Gas Heater	10 Years	10 Years
Cozy Blue Flame Vent Free Heater	N/A	10 Years
Cozy Infra-Red Vent Free Heater	N/A	N/A

LOUISVILLE TIN & STOVE COMPANY

737 S. 13TH STREET - LOUISVILLE, KY. 40210